



Rotary Rake ZGR-420



Operator's Manual

Rel. 09/24

Page left blank intentionally

Table of Contents

1. Introduction	4
2. Machine identification.....	5
3. Guidelines for safe operation	6
3.1 User safety	6-9
3.2 Residual risk assessment	9-10
3.3 Warning decals on the machine.....	11-12
4. Intended use of the machine	13
5. Description of the machine.....	14
5.1 Technical characteristics - technical details	14
5.2 Technical characteristics – major components.....	14-15
6. Operating principals	16
6.1 Attaching to tractor.....	17-19
6.2 Preparing the machine for operation	18
6.3 Preparing the machine for transport	19
6.4 Raking and forming of windrows.....	20
6.5 Tine arms operation.....	21-22
6.6 Folding and unfolding of safety barriers	23
6.7 Swath width adjustment	24
6.8 Working height adjustment	25
6.9 Ground contour tracking	26
6.10 Throttle valve adjustment.....	27
7. Lubrication and maintenance	28
7.1 Inspection and maintenance of raking tines	29
7.2 Post–operation maintenance.....	30
7.3 Lubricating machine.....	30-33
7.4 Post–season maintenance	34
8. Disassembly, disposal and environmental protection	35
9. PTO Driveline Instructions	36-39
10. Torque Specifications.....	40
10. Parts Breakdown.....	41-61
11. Warranty.....	62

Introduction

1. Introduction

This document covers the most recent data available at the date of its publication. Due to the development of the product some of the drawings and parameters described may not fully represent your machine. The manufacturer reserves the right to introduce changes in construction and design of the machine in order to improve its safety and functionality without making any amendments to the operating manual if the modifications can be considered as minor and not affecting operator's safety and working principals of the machine stay as before.

A full and thorough reading and understanding of all sections of this manual should be completed prior to trying of the machine for the first time. The rules and recommendations contained in this document must be adhered to at all times.



CAUTION

Familiarize yourself with the operating manual prior to operating this machine.

This operating manual contains the description of all risks, which may occur in case of not observing the safety rules when operating and maintenance of this rotary rake. The safety precautions are listed in this document and should be adhered to in order to minimalize or avoid the risks.

This manual explains working principals of the machine and contains instructions on how to carry out all operations with this machine safely.

In case of any doubt arising or if the information in the manual is insufficient, please ask the manufacturer directly for detailed explanation of the issue.

CAUTION



This symbol represents danger or warning. This symbol highlights the place in the manual where there is important information about the need for special care and attention. Reading of this section and adherence to the recommended safe operation is compulsory.

Machine Identification

2. Machine Identification

The ZGR Rotary Hay Rake can be identified by the serial plate. The plate is located on the main headstock of the machine, in a prominent location and easy to access. Under no circumstances should the identification plate be removed from this machine or used for another machine.



Note: If replacement parts are needed, warranty or service issues arise, it is imperative to give the Model Number and Serial Number of the machine to accurately identify the machine.

Guidelines for Safe Operation

3. Guidelines for Safe Operation

3.1 User safety

This machine rake can be operated only by a qualified adult person, familiarized with its operating principals and the content of the operating manual. The machine should be always handled with utmost care.

- The Basic Health and Safety rules should be used in addition to the recommendations included in this operating manual. Always comply with warning symbols on the machine.
- The operator must have the sufficient qualifications to drive a vehicle to which the hay rake is attached, in compliance with the manufacturer recommendations or current legislation.
- Be vigilant for places on the machine posing injury risk (sharp or pointed edges of the machine, etc.). Exercise due caution near critical places, especially whilst performing any kind of task requiring being close to the machine e.g. service, maintenance, making manual adjustments etc. Protective outfit should always be worn including protective clothing, gloves, safety boots and protective goggles.
- Read operator's manual prior to use of this implement in order to familiarize yourself with its working principals, risk management and recommendations regards operation and adjustment.
- Do not use the hay rake with any missing factory-provided guard or cover limiting access to hazard zones. Keep all safety guards and covers in working condition and check regularly for their completeness.
- Due to the residual risk involved, it is imperative that all the rules and recommendations featured in this operating manual as well as common sense are followed at all times. Reasonable conduct is advised.
- Under no circumstances the machine should be operated by persons being under the influence of alcohol or of any other intoxicating agent.
- This machine should be only operated by the driver of the tractor (no passengers allowed). No one should remain in the vicinity of this machine whilst working.
- Do not use this implement against its intended purpose. Other than intended by the manufacturer use will be considered as misuse and will void the warranty as well as will exempt the manufacturer from liability for damage caused as result of such conduct.
- In case of any doubt arising regards this machine or any piece of information included in this document, please ask the manufacturer or your dealer for detailed explanation of the issue.
- Misuse, reckless behaviour around the machine and ignoring of the warnings included in this operating manual can pose unnecessary threat to life, health.
- It is recommended to check the technical condition of the machine every time before work commencement. Pay special attention to the condition of headstock, linkage pins, safety pins, chassis, PTO shaft safety covers, safety guards, crop tines etc. It is forbidden to operate the machine out of order.

Guidelines for Safe Operation

- Do not carry persons or things on the machine.
- Before linking to the tractor, place the machine on a hard, flat surface, lower down the support stands and lock the chassis in place by means of wheel blocks. Beware of potential stabbing hazard whilst moving near the arms which are folded in the transport position. To reduce injury risk always cover upwards facing tines with the provided protective yellow sleeves at all times..
- **Do not power up the machine with the rotor arms in the transport position. Powering up the rotor when locked in place can cause permanent damage to the rotor gearbox and the power take off drive line.**
- No one is allowed to stand in-between the implement and the tractor whilst connecting the tractor three point linkage. This area is considered a crush zone.
- Extra care must be exercised when linking the implement to the tractor.
- The headstock of the machine is designed for use with rear tractor three point linkage of category I/II and it should not be used with any different category.
- To secure three point linkage pins from falling out use only typical cotter/ lynch pins supplied by the manufacturer. Work with non-standard safety pins or without any safety pin is forbidden.
- Make sure the correct type of PTO shaft is used and it has suitable movement within the operation zones, if in doubt, consult operator's manual for PTO shaft.
- Do not use PTO shaft with no safety covers on or when the safety covers or the PTO shaft itself are damaged. Remove the fault if possible or replace the item with new.
- To prevent the PTO shaft safety cover from spinning, connect the safety chain to a rigid, not moving element of the machine.
- Always have the PTO shaft connected to the tractor and to the machine to prevent damage in transit. Do not use safety chains of the PTO shaft to support it whilst in transport.
- After connecting the PTO shaft check the correctness of the connection at both ends. Make sure that safety covers and chains are in place.
- Before you power the implement up:
 - Make sure that the direction of rotations of the PTO shaft is correct.
 - Check if the tine arms are set in correct position and are appropriately secured.
- Make sure no one stays in the hazard zones. Be especially vigilant for children and animals. The Operator is responsible for keeping sufficient visibility of the machine and work area.
- The rotary rake should not be used or transported at night or when the visibility is poor as it creates unnecessary risk of an accident involving other road user.
- Do not exceed the PTO operating speed at 540 rpm.
- Avoid placing of the drive assembly under sudden load whilst starting work. Always increase the rotations gradually.
- **It is imperative to cut off the power supply from the tractor before reversing the tractor with the mounted machine or before making U-turns. Manoeuvring with the powered machine can cause damage to the drive assembly.**

Guidelines for Safe Operation

- Do not leave the driver seat when the machine is powered.
- It is the Operator's responsibility to make sure that no one comes within 50 m distance of the rotary rake whilst working due to the risk of ejecting object or coming into contact with hazard zones e.g. rotating parts.
- Make sure that the raking tines are set in correct position before starting work with the implement.
- Do not place your fingers or limbs in positions where they could be cut, crushed or trapped.
- Under no circumstances are you allowed to come in vicinity of the rotor or PTO shaft whilst in move.
- Before disconnecting the PTO shaft switch of the engine of the tractor, remove the ignition key and engage the hand brake.
- All operations should be done observing the Basic Health and Safety rules. In case of injury the wound should be immediately rinsed and disinfected.
- Any maintenance or repair works can be done only after the engine of the tractor was switched of and the ignition key was removed.
- Use protective gloves and appropriate tools whilst performing any work by the machine.
- Stop all operations immediately if any malfunctions or damages were revealed.

NEVER OPERATE A MACHINE THAT IS IN NEED OF REPAIR OR IS DAMAGED.

- To keep your machine safe and operable check its technical condition regularly. Pay special attention to all separable connections. Lubricate the greasing points following the manufacturer's recommendations. Inspect the condition, completeness and operability of all assemblies of the machine. Keep the correct tire pressure. Replace the damaged or worn part with new.
- Do not work under raised, unsecured machine. Use only attested, fully operable hoisting equipment of sufficient lifting capability. It is imperative to use additional solid supports to ensure safety in case of hoisting equipment failure. Never block the tires of the machine with fragile objects such as bricks or concrete blocks.
- Do not wear loose fitting clothes such as coats, unzipped or unbuttoned jackets or fleeces, scarfs or loose straps near the machine and tie the long hair up in a bun to minimize the risk of being caught by the rotating elements of the machine such as PTO shaft or the rotor. Under no circumstances come near the machine when it is powered or still in motion. Exercise special care whilst performing any service or maintenance task near hazard zones.
- When carrying post warranty service involving any welding works it is imperative to follow the rules listed below:
 - The welding works should be done by a qualified person.
 - Ensure there is sufficient lighting and ventilation in the work area.
 - Do not weld a tractor mounted machine due to the risk of fire or electrical short.
 - After removing the layer of paint and primer, clean and degrease the surface intended to weld. Remove excess of lubricant from the nearby grease points.
 - To minimize the risk of causing fire remove all inflammable elements of the machine if possible or use sufficient heat protection. Do not touch freshly welded surfaces to avoid the risk of burns.

Residual Risk Assessment

3.2 Residual risk assessment

Tar River Implements has made every effort to eliminate the risk of an accident. However, there is some residual risk, which can lead to an accident, and is primarily associated with the actions described below:

Residual risk

<i>NO</i>	<i>Risk</i>	<i>Risk source (cause)</i>	<i>Precautions and prevention</i>
1	Overload of the muscular and skeletal system (physical stress)	Working in standing, stooped or forced position, walking, moving heavy objects around	Familiarizing with the operating manual, operator's basic health and safety regarding manual lifting. Assess whether you need assistance to lift an object or use correct tools to assist you e.g. back belts, trolleys or mechanical aids to achieve movement.
2	Trip hazard and slippery surfaces	uneven ground, obstacles, poor visibility, slippery or wet surfaces, untidy operating areas and walkways e.g. electric leads on the ground	Always be precautionous, use footwear with a good grip and work with adequate light. Never obstruct walkways and take great care when walking on uneven or wet surfaces. Do not run in restricted areas. Keep your work area tidy.
3	Risk of walking into fixed, protruding parts of the machine	the machine and its surrounding	Beware of protruding parts whilst servicing the machine. Keep the walkways clear. Take special care whilst near the machine. Always wear protective clothing. Secure the raking tines which are pointing upwards in transport position by means of protective tarpaulin sleeves.
4	Risk of being hit by moving objects or parts	material discharge, stones	Observe ground conditions, make sure all bystanders are at least 50 meters away whilst working with the machine. Always wear protective clothing, hard hat and goggles. Do not come in vicinity of the machine whilst powered or still in motion. Take special care whilst servicing rotating or moving parts of the rotary rake.
5	Sharp edges	exposed sharp edges, hand tools	Wear personal protection clothes and gloves at all times. No flappy clothing allowed. Take special care whilst near the machine.
6	The weight of suspended machine	Wrong assembly, badly made connection to the tractor or adjustment of the machine. Not complying with Health and Safety rules, leaving the mounted machine lifted up on the tractor linkage.	Take special care whilst near the suspended machine. Use protective outfit at all times- safety boots, safety gloves. Whilst performing inspection or service works use correct tools to lift up and secure the rotary rake in place to avoid risk of being crushed under the machine. Use assistance of the other trained person. Read operators manual carefully.

Residual Risk Assessment

7	Microclimate – changing weather	Work performed in unsettled weather conditions	Proper protective outfit, beverages, protective cream with filter, rest
8	Noise	excessive rotations of the machine; damaged, loose or vibrating parts	Work only with fully operable machine. Control regularly condition of all assemblies of the machine. Follow the recommendation regards appropriate rotations.
9	Head injury	Standing in crash zone when unfolding the safety barriers	Take special care when unfolding the safety barriers. Keep out of the crashing zones. Do not remove safety springs protecting against free falling of the barriers. Read the operators manual carefully.
10	Crushing injuries of the body	Sudden release of energy accumulated in the springs e.g. during service works	Exercise extra caution with spring loaded elements of the machine. Provide service works only when the machine and its elements are positioned in a safe way. Wear personal protection clothes, boots and gloves at all times. Use help of other qualified person when needed. Use correct tools. Do not work in hurry. Reasonable conduct advised.
11	Crushing injuries of the legs and cutting injuries of hands,	The crop deflector is mounted on a telescopic bracket and it is possible that the inner box profile of that bracket may get stuck inside the outer box profile.	Exercise extra caution. Do not work in hurry. Wear personal protection clothes, boots and gloves at all times. To release the element that got stuck, first try to move it sideways a little.
12	Risk of being trapped or pulled in	Staying near the hay rake when it is altering position e.g. when at work; rotating or moving parts of the machine; PTO shaft; not using safety barriers.	Beware of danger and never come close to the machine or driveline when in motion Do not wear loose fitting clothes. Wear clothes that will not snag on the machinery instead- preferably overalls. Remove jewellery that may snag - e.g. watch, rings, necklace. Keep long hair tied up. Read the operating manual carefully. Respect safety pictograms placed on the machine.

Warning Decals

3.3 Warning decals on the machine

Safety decals



1.0 – Caution. Prior to operating the machine, read the operating manual.

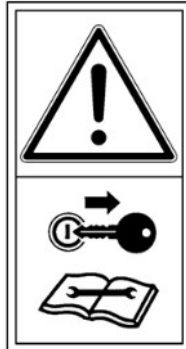

1.1 – Caution. Stop the engine and remove the ignition key before carrying out any repairs or maintenance.



1.2 – Thrown objects, pull-in accidents and other hazards. No persons allowed in distance less than 165 feet from the working machine.



1.3 – Caution. Wrap point - exposed, rotating driveline.



1.4 – Cutting hazard - Free moving parts. Do not touch rotating elements while in motion.



1.5 - Crush point. Keep away from linkage arms of the tractor hydraulic lift while in use.



1.6 – Caution. Entanglement, Exposed rotor assembly.











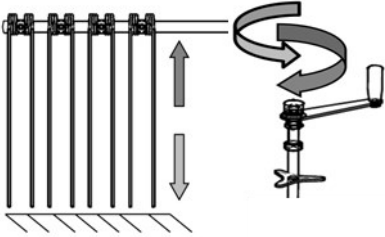

1.7 – High voltage - risk of electric shock. Keep sufficient clearance from power supply lines.



1.8 – Crush hazard. Keep away from the swing area around the safety barriers.

Warning Decals

 <p>1.9 – Do not exceed the PTO operating speed at 540 rpm.</p>	 <p>1.10 – Correct position of the raking arms for chosen function: TRANSPORT- transport; PRACA- work.</p>	 <p>1.11 – Lift point</p>
 <p>1.12 – Raking height adjustment</p>	 <p>1.13 – Transport lock – It is imperative to lock the tine arms in transport position before transport on a public road</p>	 <p>1.14 – Lubrication point- use solid grease</p>
 <p>1.15 –Lubrication point- use oil to grease.</p>	 <p>1.16 – Do not exceed maximum tire pressure</p>	 <p>1.17 – Use ear protection</p>
 <p>1.18 – Use protective clothing</p>	 <p>1.19 – Use safety gloves</p>	 <p>1.20 – Use eye protection</p>

Intended Use of the Machine

4. Intended use of the machine

This rotary rake was designed for agricultural use in process of production of animal feed and bedding. It is intended for raking cut grass, hay or straw in uniform windrows or swaths. Machine should be use on stonless meadows or pastures where where stones were removed. Large stones can cause unnecessary machine damage.

Use of the machine in conditions other than above mentioned will be understood as its misuse. The manufacturer's recommendations and provisions mentioned in this operating manual should be strictly adhered to every time the machine is operated, maintained or serviced. Not applying to those rules will be considered as use of the machine against its intended purpose.

The machine can be operated, maintained and serviced only by trained personnel familiarized with its technical characteristics and Health and Safety rules.

The applicable provisions of Health and Safety as well as Highway Code should be adhered to at all times.

Unauthorized changes made without consent of the manufacturer will void the warranty and exempt the manufacturer from liability for damage caused as result of those changes.



All obscurities concerning intended use of the devices hall are explained by contacting with the machine manufacturer. Proper selection of a machine and the conscious of its intended use shall increase the operation safety.

Using the machine for purposes other than accepted shall be considered misuse.

Description of the Machine

5. Description of the machine

5.1 Technical characteristics - technical details

Lp.	Description	Unit	Value/Type	Unit	Value/Type
1	Overall length in transport position	[mm]	4700	[ft]	15'-4"
2	Overall length in working position	[mm]	4800	[ft]	16'
3	Overall width in transport position	[mm]	2300	[ft]	7.5'
4	Overall width in working position (min.-max.)	[mm]	3910-4510	[ft]	13'-15'
5	Maximum height in transport position	[mm]	2770	[ft]	9'
6	Working width	[mm]	4200	[ft]	14'
7	Tractor horsepower requirement	[HP]	min. 35	[HP]	min. 35
8	Maximal PTO rotations	[RPM]	540	[RPM]	540
9	Recommended PTO rotations	[RPM]	300÷400	[RPM]	300÷400
10	Tare weight	[kg]	670	[lbs]	1477
11	Number of rotors	[pcs.]	1	[pcs.]	1
12	Number of rotating arms	[pcs.]	11	[pcs.]	11
13	Working capacity	[ha/h]	4-4.5	[acres/hr]	9-11
14	Working speed	[km/h]	10	[miles/h]	6
15	Noise level	[dB]	<75	[dB]	<75
16	Number of wheels	[pcs.]	4	[pcs.]	4
17	Tire size	-	18.5x8.5-8	-	18.5x8.5-8
18	Tire pressure	[bar]	3.0-3.5max	[psi]	44-50max

5.2 Technical characteristics – major components

The structure of the rotary rake is shown in Figure 2. The main elements include:

Agricultural hitch (1) articulated to the front beam (2). The hitch is additionally coupled to the frame by the link (3), which makes the hitch parallel to the ground. Attached to the main frame (4) is a gearbox (5) that provides simultaneous spinning and pivoting motion of the folding arms seated on its pivots and (9) the rigid arms (10) equipped with raking fingers. The gearbox is mounted directly on a chassis (12) with a tandem arrangement for better terrain mapping. The rake also has a swath scraper (11) equipped with a flexible screen for forming the raked mass into a single roller. The width of the formed shaft is adjustable by extending or retracting the swath scraper into the profile of the left protective barrier (7), which is secured by a cotter pin with an anti-loss element. To restrict access to the work zone, the machine is equipped with a right guard barrier (6), a left guard barrier (7) and a front barrier (8). A hydraulic system (13), supplied from one hydraulic section of the tractor, is responsible for lifting the machine to the transport position. It includes, among other things, two cylinders- responsible for evenly raising and lowering the machine, two throttle valves- responsible for adjusting the operation of both cylinders, hoses, hydraulic fittings, etc.

Description of the Machine

Technical characteristics – major components

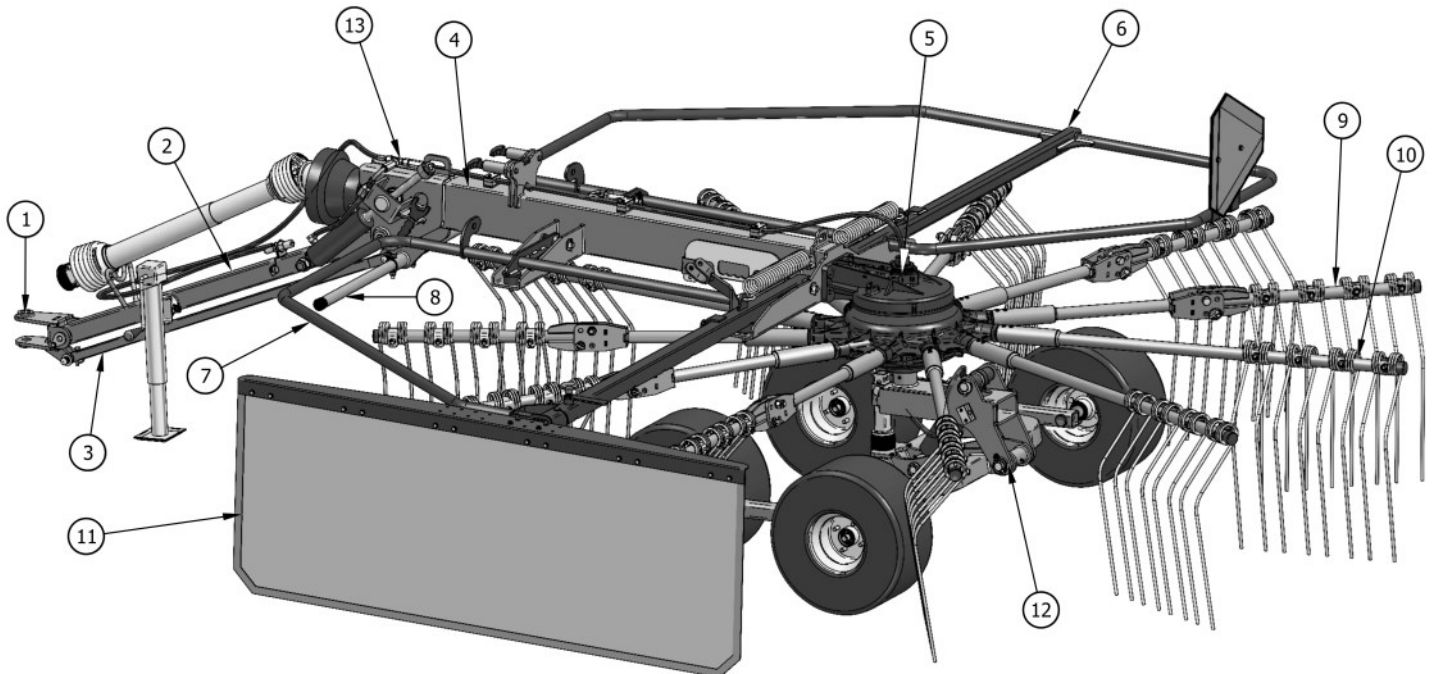

Figure 2. Single-rotor hay rake – main components

Legend:

1. Hitch weldment
2. Intermediate beam
3. Hitch link
4. Main frame
5. Main gearbox
6. Safety barrier - right
7. Safety barrier - left
8. Central cover
9. Foldable raking arm
10. Rigid raking arm
11. Apron
12. Chassis
13. Hydraulic tee

Operating Instructions

6. Operating instructions

The manufacturer ensures that the machine is fully operational and has been checked according to the quality control procedures and approved for use. However, this does not relieve the user from the obligation to check the machine after delivery, prior to starting it for the first time. Before performing any task concerning attaching of the hay rake to the tractor inspect its technical condition and prepare it for the trial start up. Follow the steps listed below:

- a) Familiarize yourself thoroughly with all pieces of information described in this operating manual, especially concerning the User's Safety, built of the hay rake, its functioning and operating principals, transportation, service and maintenance recommendations etc.
- b) With help of this operating manual, familiarize yourself visually with the built of the rotary rake and placement of the safety alert pictograms located on the machine near the specific hazards. Make sure that you recognize thoroughly the meaning of all safety labels and what kind of danger do they represent. Be cautious when near the machine.
- c) Check if the machine is complete, especially that all separable connections e.g. threaded bolts, nuts, linkage pins, safety cotter/lynch pins etc. are not missing.
- d) Make sure that all threaded connectors are tight.
- e) Check the condition of the tires and tire pressure.
- f) Check if the wheels are attached properly to the undercarriage.
- g) Check the condition of paint coating.
- h) Visually inspect the machine for any signs of damage incurred before or during delivery especially when loading/ unloading or in haulage. Be vigilant in particular for fractures, dents, cracks, punctures etc.
- i) Check if all the greasing points were primed with lubricant. Supplement the lubricant if needed. Follow the recommendations of the manufacturer as described in the chapter „Service and maintenance”.
- j) Inspect if the raking height adjustment mechanism work correctly.
- k) Make sure that the raking arms are attached properly to the rotor.
- l) Check the condition of the raking tines and if they are bolted up correctly to the raking arms.
- m) Make sure that the safety barriers were mounted in a correct way and are fully operable.
- n) Check the condition of the swat deflector, especially its tarpaulin shield.
- o) Inspect the condition and completeness of the headstock and linkage connectors. Make sure that nothing got damaged in transit and there are no missing elements e.g. linkage pins, lynch pins, safety cotters etc.
- p) Check the gearbox against the leakages. Make sure that the level of oil in the oil compartment is sufficient.

Operating Instructions

6.1 Attaching to tractor



Caution!

Read the Operator's Manual before attaching the rake. In addition, always pay special attention to maintain safety when attaching the machine to the tractor.

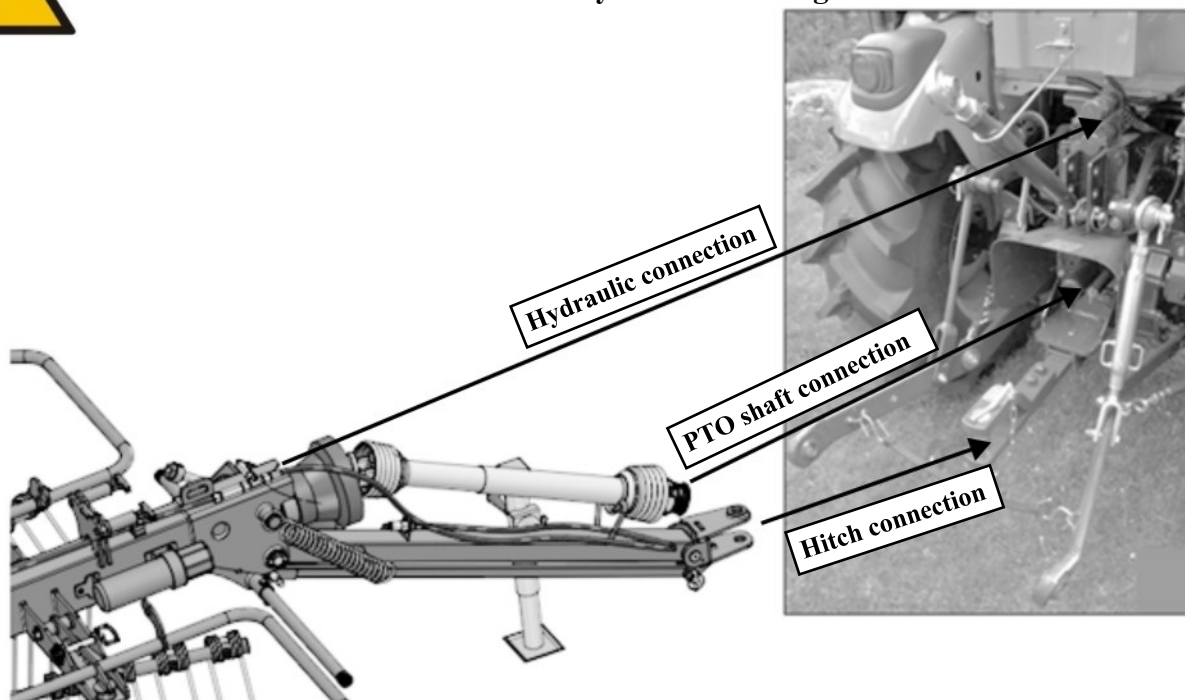



Figure 3. Attaching rotary rake to the tractor.

Attaching the Rotary Rake

- It is best to attach the rotary rake to the tractor on a solid level surface.
- Back up the tractor to the rotary rake, while lining up the lower tractor hitch to the rotary rake hitch. If the hitches do not line up, adjust the rotary rake foot stand up or down to match tractor hitch.
- Always stop the tractor engine, set the brake and remove the key from the tractor and block the tractor tires before attaching the rotary rake.
- Secure the tractor hitch to the rotary rake with hitch pin and lynch pin.
- Connect the PTO to the tractor and rotary rake.
- Connect the rotary rake hydraulic hose to the tractor hydraulics. Always use caution when working around hydraulics. See “Warning” below.
- Retract the rotary rake's foot stand before moving the tractor and rotary rake.



⚠ WARNING

- Avoid serious injury from injection of pressurized hydraulic fluid.
- Always relieve pressure before performing service or maintenance on any hydraulic components. Refer to tractor and implement Operator's Manuals.
- Do not use hands to search for leaks. Use cardboard or similar material.

Operating Instructions

6.2 Preparing the machine for operation



Note

Before each use of the rake, check its technical condition. In particular, check the technical condition of the rake system, the driving system, the set of safety guards, the correctness of the attachment of

Transported to the work site, the rake must be unfolded to the correct working position. Adaptation of the machine for operation can only be done at the site where the rake will be operated. It is forbidden to drive the machine on roads with the rake arms and guards spread out!

The sequence of steps involved in preparing the rake for operation directly at the work site:

- on flat ground, lower the rake onto the ground to rest freely on the wheels,
- immobilize the tractor and protect it from free movement,
- leave the driver's cab and go to the machine,
- remove the protective covers from the folded arms,
- unlock the folding arms from the transport lock and unfold to the working position according to the information in section 6.5,
- unlock and deploy safety barriers according to the information in section 6.6,
- set the required swath width according to the information in section 6.7,
- set the required rake height according to the information in section 6.8,
- check the installation of the PTO shaft,
- check that all pins are secured from slipping out with pins, perform a trial run of the machine at low PTO speed to check the proper functioning of all components. The trial run should last a few minutes. During the test, it should be determined whether there is unnatural crackling, grinding or rattling coming from the drive system, whether the direction of rotation of the rotor is correct, and whether the cam mechanism causing lifting and lowering of the arms is functioning properly. The operation of the rake at idle should be smooth and without much vibration. You should not hear ringing, vibrating or other sounds indicative of loose screw connections.
- In addition, after stopping the machine after a trial run once again check the general condition of the transmission system including the complete rotor for damage and leaks. If there are symptoms of a malfunction, locate the exact location of the malfunction and fix it. If the malfunction is serious and cannot be easily corrected, contact your dealer to solve the problem.

Operating Instructions

6.3 Preparing the machine for transport

After finishing work, the machine must be folded into the transport position and properly secured for transport. When you have finished working, turn off the tractor engine and remove the ignition key. Next, immobilize the tractor by applying the parking brake and protect the driver's cab from intrusion by bystanders while preparing the rake for transport. Remember that driving on public roads is prohibited after dark and in conditions of reduced visibility.

Start work by folding the swath screen. Actions analogous to unfolding except that in reverse order (see information in section 6.7). Then assemble the protective barriers. Actions analogous to the unfolding except that in reverse order (see information in section 6.6). The next step is to fold the folding arms. Carry out folding operations analogously to unfolding except that in reverse order (see instructions in section 6.5).

Then place protective aprons over the protruding rake fingers and secure them from slipping off by tying the cords. It is also recommended to remove the articulated-telescopic shaft. However, if the shaft had not been dismantled, **remember the strict prohibition of activating the shaft drive during transport.**

After the operations, go to the operator's cabin again, start the tractor and lift the machine up using the linkages. When the machine is lifted, the main pin connecting the frame to the hitch moves in the slot as far as it will go, at the same time the control links are shortened, stiffening the machine permanently during transport. When lifting the rake, the zone between the tractor and the machine should be controlled at all times so that the upper hitch and barriers do not collide with the driver's cab.

Operating Instructions

6.4 Raking and forming of windrows

The working element of a rotary rake is the rotor. The rotor consists of a reduction gear equipped with pivots on which the rake arms are mounted.

With the help of the power take-off (PTO) shaft, torque is transferred from the tractor to the intermediate shaft, which transmits the drive directly to the transmission. The gearbox, as a result of the applied torque, performs rotary motion of the rotor. In addition, each arm is equipped with a cam mechanism, also embedded in the gearbox body, which gives it a swinging motion. This movement causes the raking fingers entering the raking phase to position themselves vertically and take the encountered swath with them. As the raking arm approaches the swath forming zone, the cam mechanism causes the raking fingers to rotate and lift so that they lose contact with the raked mass, which, due to centrifugal force, is freely ejected in the direction of the roller forming screen. The phase of lifting the fingers continues until they enter back into the raking phase, where they are again lowered in the working phase. Cyclic operation according to the above scheme allows the formation of an even roll from the raked swath.

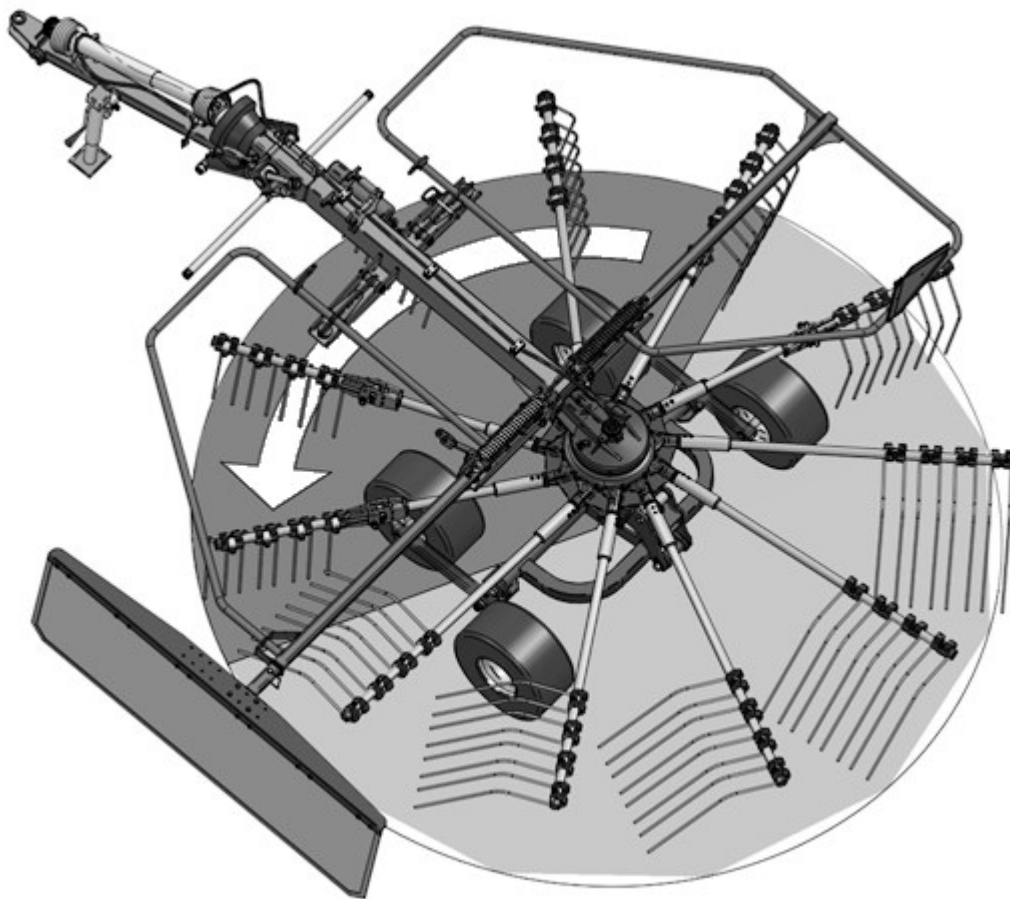

Fig.4. Working principle of the rake – the darkened area corresponds to the working phase (the rake is lowered)

Operating Instructions

6.5 Tine arm operation

Before proceeding, unfold the folded rake arms to the correct working position. To do this, start with the arm, which is also embedded in a transport lock that prevents the rotor from rotating freely during transport.



Warning!

Never operate the rotary rake if the arms are not extended and the safety barriers are not lowered! Always make sure that all arms are in the working position and safety barriers are down prior to operating the rotary rake.

To perform the steps involved in preparing the machine for operation, you need to:

1. Remove the protective aprons from the folded arms. The protective aprons are made of bright yellow tarpaulin. They are designed to warn, protect and guard against access to sharp protruding rake fingers that point upward during transport. Despite the additional steps taken to improve safety, special care should still be taken when folding, unfolding as well as staying in the area of these arms when they are folded into the transport position. After the work is done after the machine is prepared for transport, the protective aprons should be put back on the protruding fingers of the rake and remain on them until the machine is used again.
2. The next step is to unfold the first arm, which further secures the machine against free rotation of the rotor during transport. To do this, unlock the pin and remove the arm retaining pin in the transport lock. Then unfold the arm to the working position and secure it in this position by placing the locking pin in the correct hole. The pin should also be secured against being displaced with a safety pin.

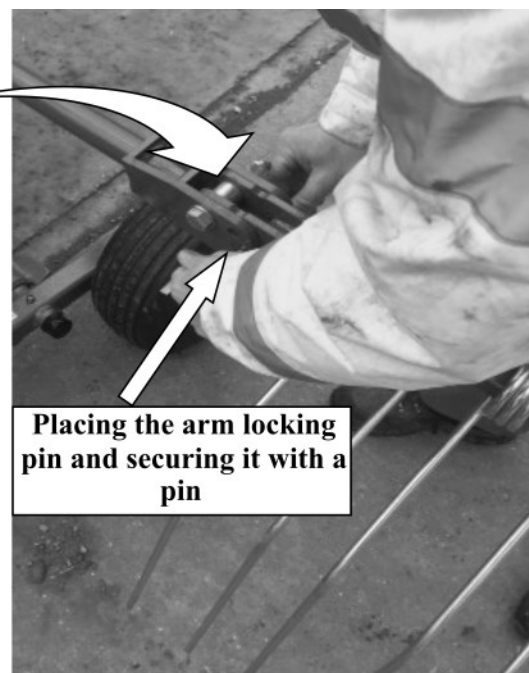
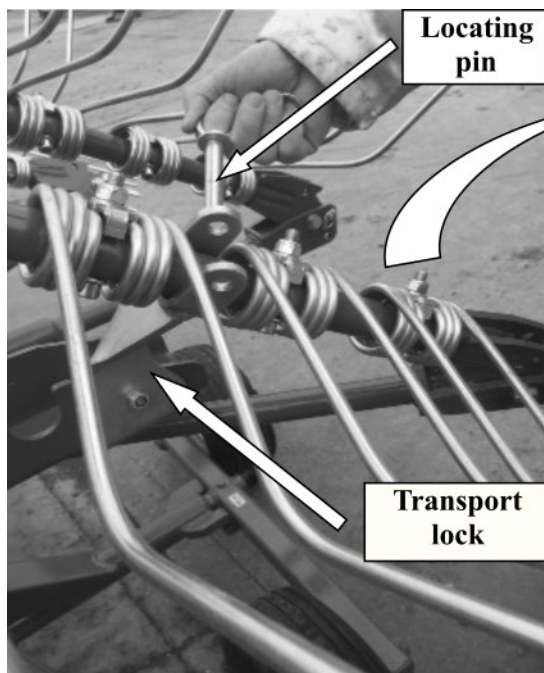

Operating Instructions

3. After unfolding the first arm, repeat the unfolding steps for the other arms (according to the diagram below):
 - a. Removing the safety pin
 - b. Unfolding the arm to the working position
 - c. Fixing the arm in the working position by placing the locking pin in the suitable hole
 - d. Securing the bolt with a pin



Warning! Never fold or unfold the arms with the tractor or rotary rake running. Serious injury or death is possible. Always fold or unfold arms on level ground.

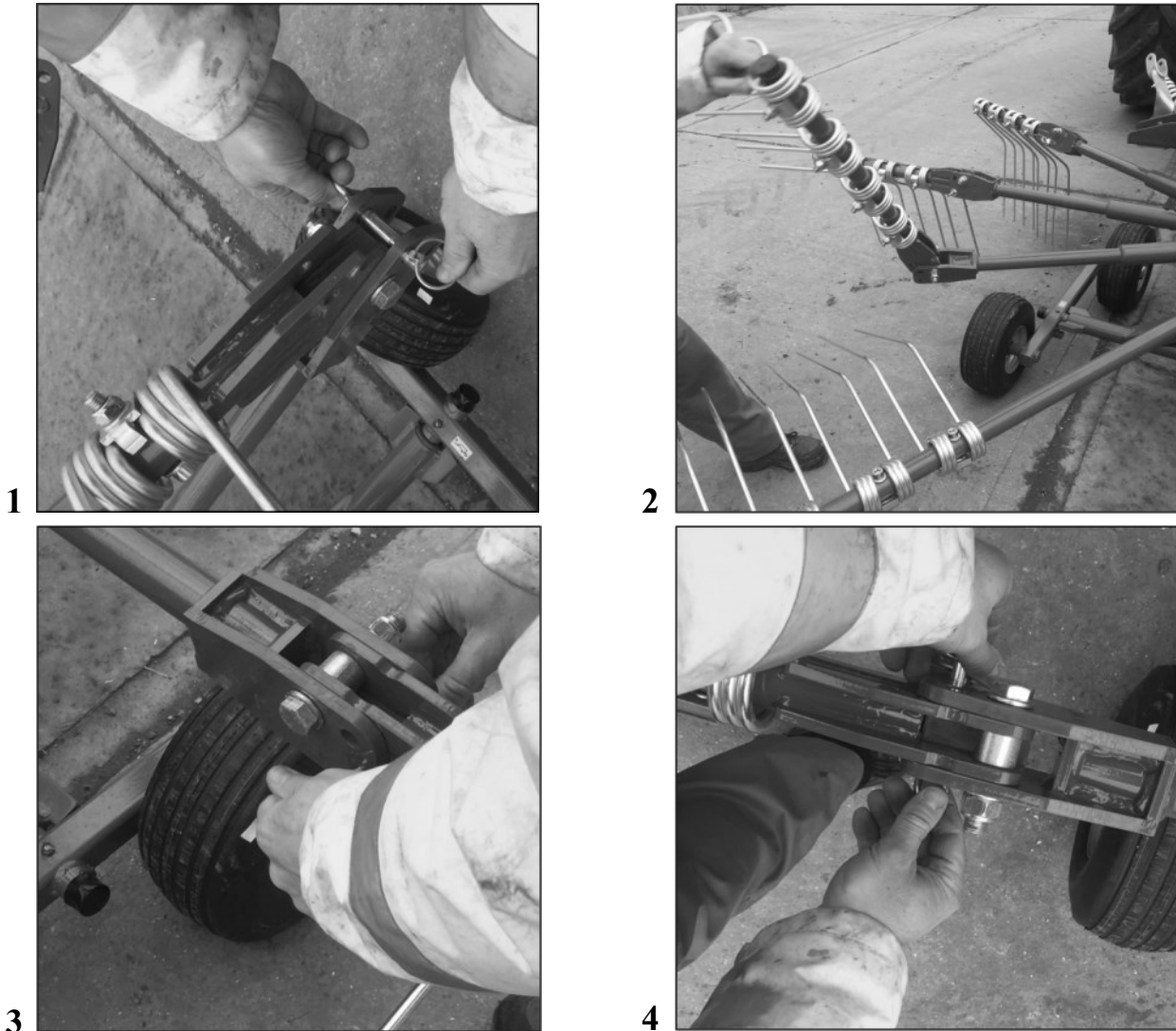

Fig. 6 Preparing the folding arms for operation

The preparation of the arms for transport is similar to preparation of the arms for work with the only difference being the reverse order.

Operating Instructions

6.6 Folding and unfolding of safety barriers

The main safety requirement is to limit the access of the user or outsiders to the working area of the machine. For this purpose, the machine has been equipped with safety barriers, which must absolutely be lowered even before starting work.

The activity of unfolding the safety barriers should be carried out sequentially after unfolding the arms. To unfold the barriers, remove the safety device (1) and insert it into the prepared place on the main frame, grasp the bolt lever (2) with a firm grip and pull it towards the hitch until the spring tension is overcome and resistance is felt. Then, grasping the barrier with the other hand, pivot in the direction of unfolding (3) and release the tension of the bolt. When releasing the bolt, use two hands to securely grasp the barrier and gradually lower it until the barrier rests on the main frame, on rubber bumpers. Further secure the right barrier with a pin (marked with the letter "A" in the figure below). Pay attention and be vigilant not to be in the lowering zone of the barrier because there is a risk of being hit by a falling barrier when the barrier slips from your hand.



Warning! Never fold or unfold the arms with the tractor or rotary rake running. Serious injury or death is possible. Always fold or unfold arms on level ground.

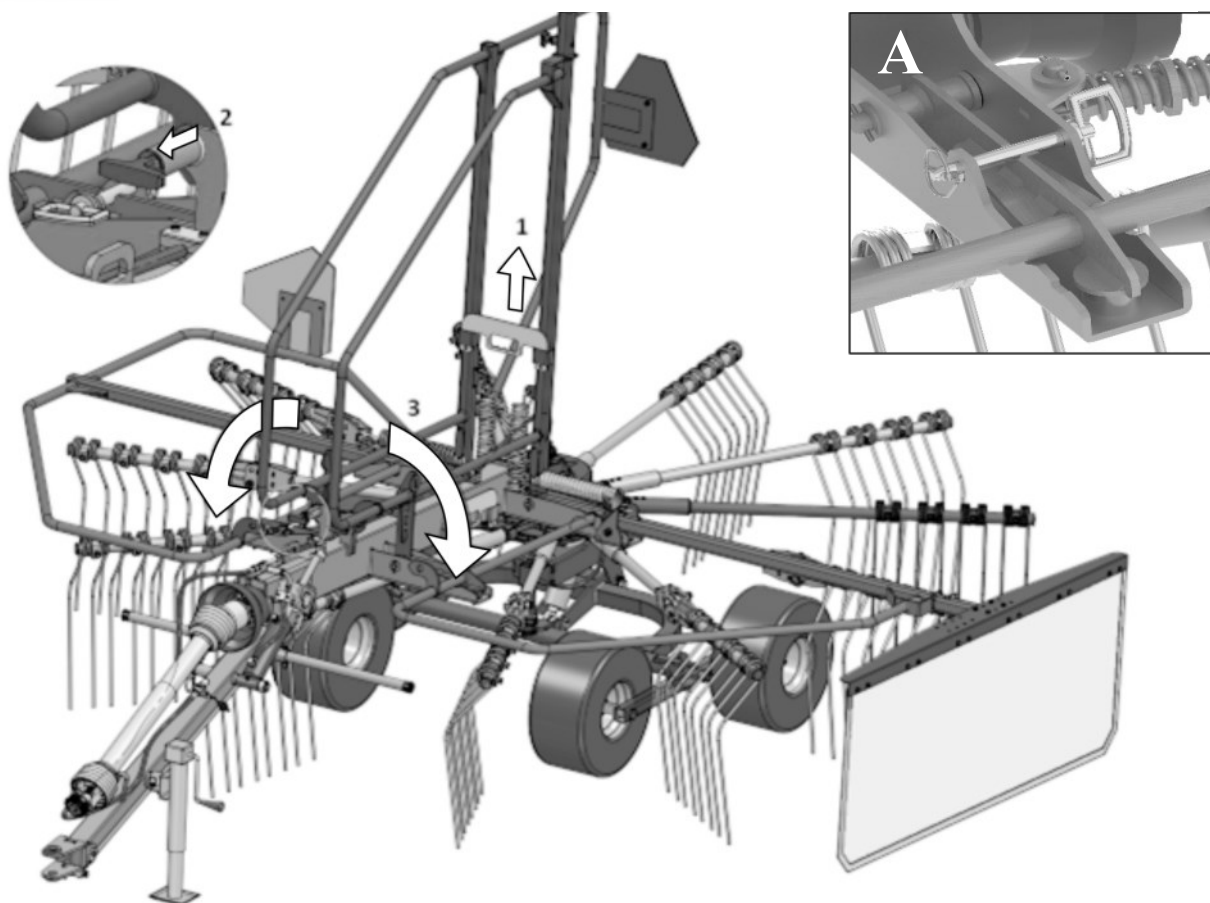

Fig. 7. Disassembling the safety barriers

The preparation of the arms for transport is similar to preparation of the arms for work with the only difference being the reverse order.

Operating Instructions

6.7 Swath width adjustment

The width of the formed shaft can be adjusted as needed. To change the width, remove the locking pin, unscrew the pressure knob and the locking lever, and then extend the scraper to the required value in the range of 0 – 620 [mm]. After adjusting, insert the pin, tighten the knob clockwise and secure the knob with the locking lever. An additional possibility to adjust the swath scraper is to change the position of the screen in relation to the bar. There are 9 positions available to the user. If you want to change the position of the screen, unscrew the 4 mounting screws, then move the screen by the required value in the range from -250 to +250 [mm]. Fixing the mounting holes in relation to each other using the previously removed screws, twist again to clearly fix the screen to the beam.

When adjusting the extension of the screen, suggest the principle that the larger the swath, the further the screen should be extended, and vice versa, with less swath, the distance of the screen should be shorter. In addition, it should be remembered that when preparing a swath for a baler or other collecting device, the width of the formed shaft should be slightly smaller than the width of the pick-up.



Caution! Disengage the power and lower the machine down on the even ground before carrying out any adjustments.

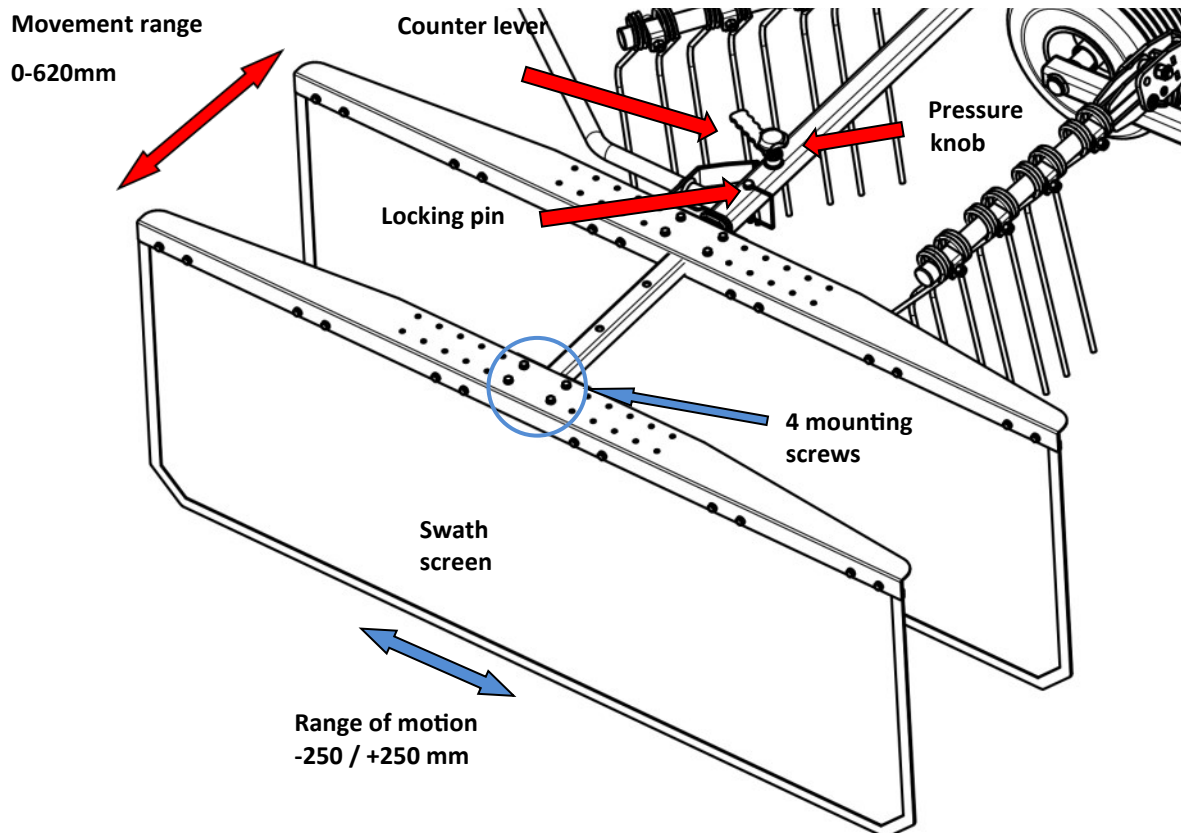

Figure 8. – Swath screen adjustment

Operating Instructions

6.8 Working height adjustment

The right raking height has a major impact on the quality of work, the cleanliness of the raked swath and the shape of the formed roll. After aggregation with the tractor, adjust the beam cylinder screw of the rake system so that it is located parallel to the ground. Determine the minimum height by locking the bumper profile with a screw connection in the corresponding hole corresponding to the desired minimum height. Depending on the amount of swath, the type of swath, the speed of raking and the terrain over which the rake will travel, the height should be selected individually by the user. It should be remembered when adjusting that raking fingers raised too high will not collect the entire swath, while at too low a height, when raking fingers penetrate the ground, the formed roller will be contaminated with stones and debris of uprooted turf with fragments of soil, and the entire drive system of the machine will be overloaded. Too much overloading will reduce the life of the raking fingers as well as the entire drive train of the machine and in extreme cases will lead to permanent damage. Depending on the need, the rake height can be adjusted smoothly with the chassis cylinder, using the tractor's hydraulic system, a function that is particularly useful on uneven terrain.



Caution! Always perform leveling and minimum height adjustment with the vehicle and machine drive off, on level ground!

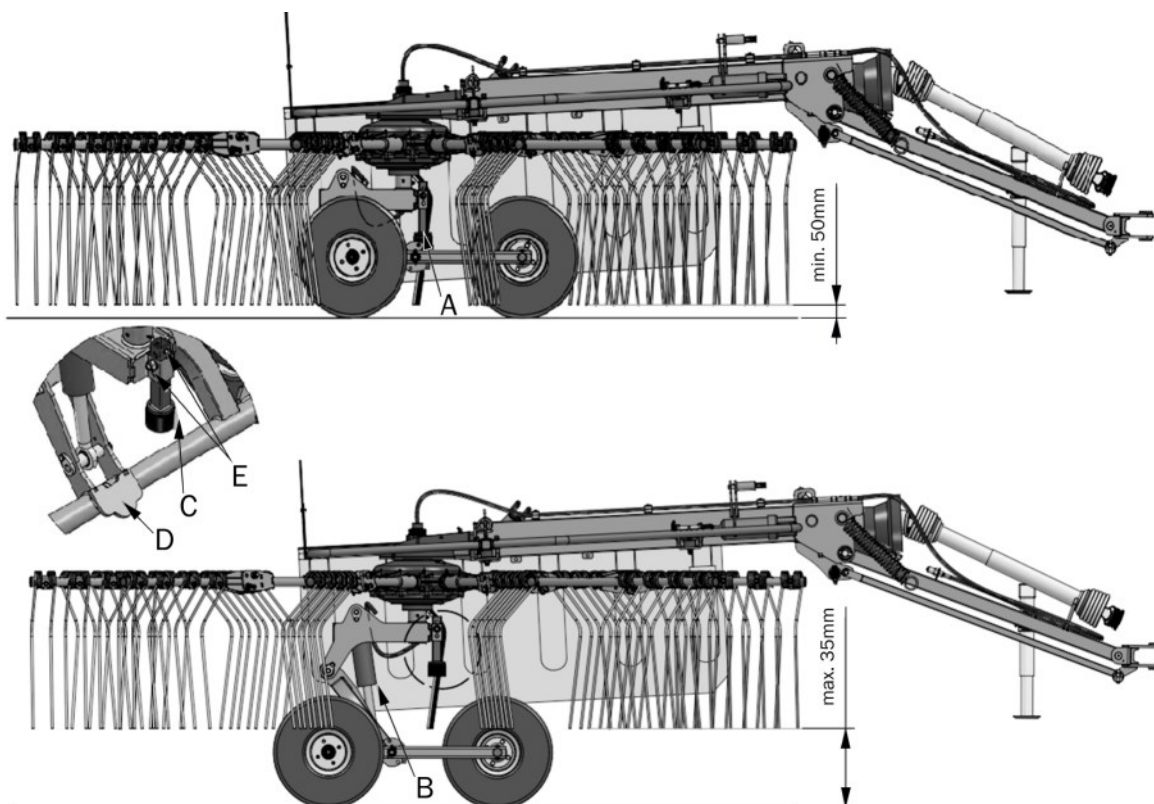

Fig. 9 Rake height adjustment

Operating Instructions

6.9 Ground contour tracking

In order to collect the raked mass as accurately as possible, the rotary rake is mounted on a pendulum running gear called a tandem. Independently operating pairs of wheels on the left and right with limited movement ensures compensation for any unevenness of the terrain. Thanks to such a solution, the operation on the machine is smooth and undisturbed..

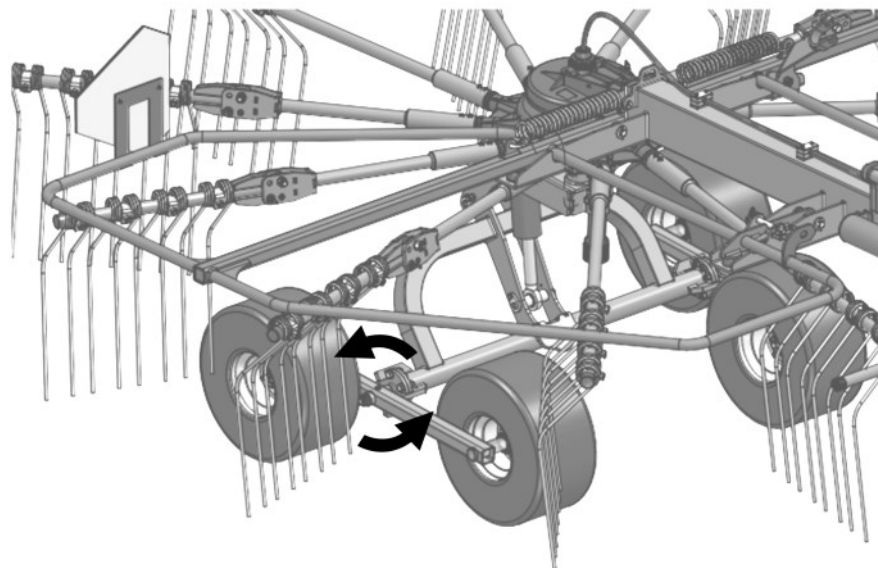

Fig. 10. Terrain ground contouring system

The hitching bar (1) with lower link (2), thanks to the hydraulic lifting system (3), allows the wheel rake to be guided over obstacles without having to lift the machine completely. This allows for stability and interoperability with much smaller tractors. Adjusting the screw (4) of the hydraulic cylinder simultaneously allows the angle of the rake to be changed relative to the ground, and the lower link (2) ensures a constant angle of the hitch (5) relative to the drawbar, both during operation and transport.

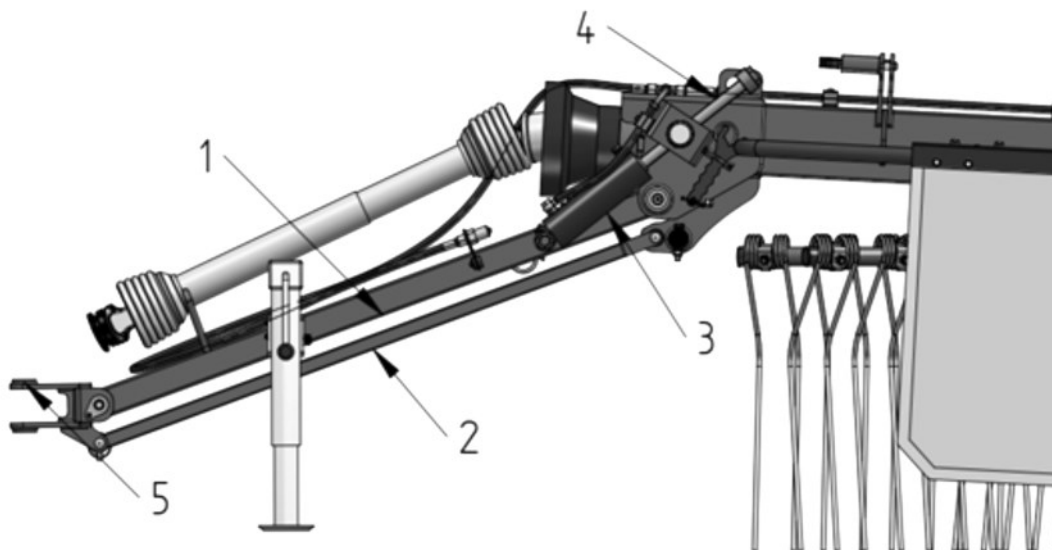

Fig. 11. Adjustable hitch system

Operating Instructions

6.10 Throttle valve adjustment

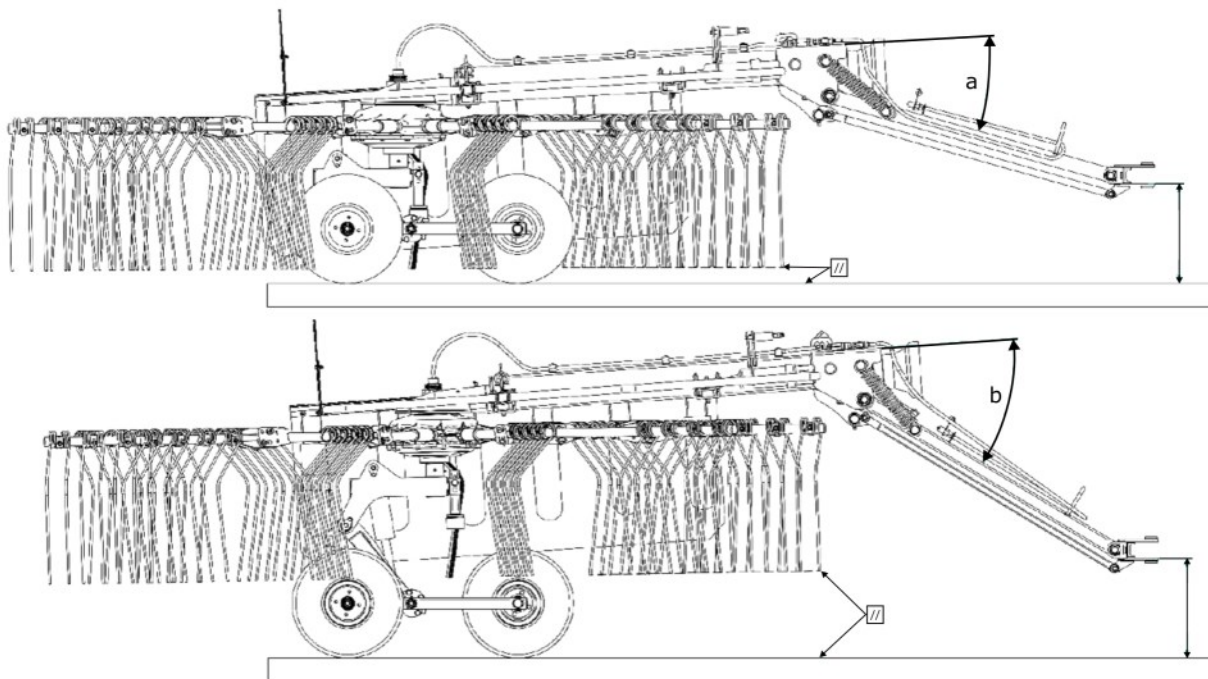

Fig. 12. Position of rake components during lifting

Proper lifting of the rake from the working position to the transport position and vice versa is possible by using synchronization of the throttle valves. The raking fingers should be parallel to the ground level at all times (during operation and during lifting to the transport position), while maintaining a constant hitch height (the hitch connected to the tractor) and with a variable angle of inclination of the intermediate beam with respect to the main frame (denoted as a change in angle α and β). Valves should be pre-adjusted by the manufacturer.

However, if there is a need for additional adjustment, it should be done as follows:

1. Connect the rake to the tractor and set it on level, firm ground (sec. 6.1).
2. Adjust the rake fingers parallel to the ground, using the cylinder screw (Figure 10 item 4)
3. Loosen the lock nut (Figure 13 items 1 and 3).
4. Adjust the valves as needed (Figure 13 item 2- chassis cylinder, item 4 hitch cylinder). Adjustment is made by rotating the valve's outer sleeve. Rotation toward the lock nut will increase the amount of oil flowing through, and rotation away from the lock nut will decrease the amount of oil flowing through the valve.
5. When the adjustment is complete, tighten the lock nuts.

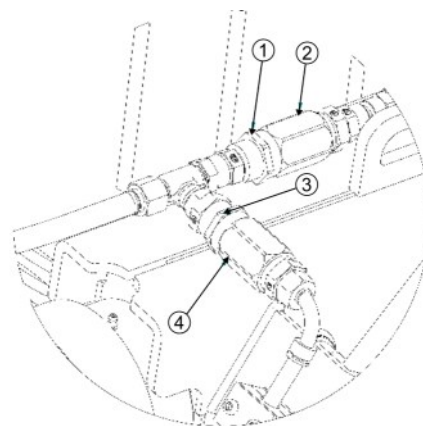

Fig. 13. Hydraulic system throttle valves

Lubrication and Maintenance

7. Lubrication and maintenance

Any operation of the machine may be performed by the operator of the vehicle to which it is connected, provided that he is authorized to operate that vehicle.



Note: The machine, when detached from the vehicle, should be stored under a canopy on a flat, firm surface and footing.

- Before connecting the machine to the tractor, the machine operator must always check the technical condition of the machine and prepare the machine for a test run. To do so:
- Familiarize yourself with the contents of this manual and follow the recommendations contained therein.
- Get to know the structure and understand the operating principle of the machine
- Perform a visual inspection of all machine components for mechanical damage
- Lubricate the machine as recommended
- Check the condition of the hitch system pins and locking pins
- Check the oil level in the gearbox
- Check the condition of the screw connections



Always use original manufacturer parts to guarantee a safe and reliable operation of the machine. Using non-original manufacturer parts OEM parts or repairing damaged parts will void the warranty.



In the case of leaks in the hydraulic system, it is imperative to replace the damaged parts and assemblies of the system so as not to contaminate the environment. Hydraulic lines should be replaced after a period of 5 years regardless of external conditions.

If all the above steps have been carried out and the technical condition of the machine does not raise any objections, you can connect it to the tractor.

It is forbidden to use an inoperative machine. Once a defect is found, it should always be corrected before using the rake again. Always perform all maintenance, inspection and repair work with the tractor engine turned off and the ignition key removed. In addition, always secure the driver's cab against intrusion by bystanders and especially children. All work should be carried out by users in accordance with all information contained in the manual. Any welding work carried out during post-warranty repair work should be done only by qualified persons with the appropriate authorizations. When welding using the electrical method, always disconnect the tractor from the machine; in addition, protect with special mats any flammable things such as covers made of plastic, etc. Any work under the machine related to its lifting should be carried out using certified lifts. However, it is always necessary to further secure the machine by additional permanent supports (do not use brittle concrete blocks!) When conducting any maintenance work, use personal protective equipment. All work should be carried out in accordance with health and safety rules.

Lubrication and Maintenance

7.1 Inspection and maintenance of raking tines

The rake finger is made of spring steel, so it can withstand dynamic loads well. Despite their high durability, they are subject to natural wear and tear due to constant contact with the ground. In addition, due to vibration, the bolted connections attaching the rake fingers to the arm may loosen. Therefore, each time before starting work, it is necessary to check the technical condition of each finger and the tension of each of the fastening screws. If any rake finger is found to be damaged, replace it with a new one. It is forbidden to repair a damaged finger.



Caution: Always perform the adjustment with the vehicle and machine drive off, on level ground!

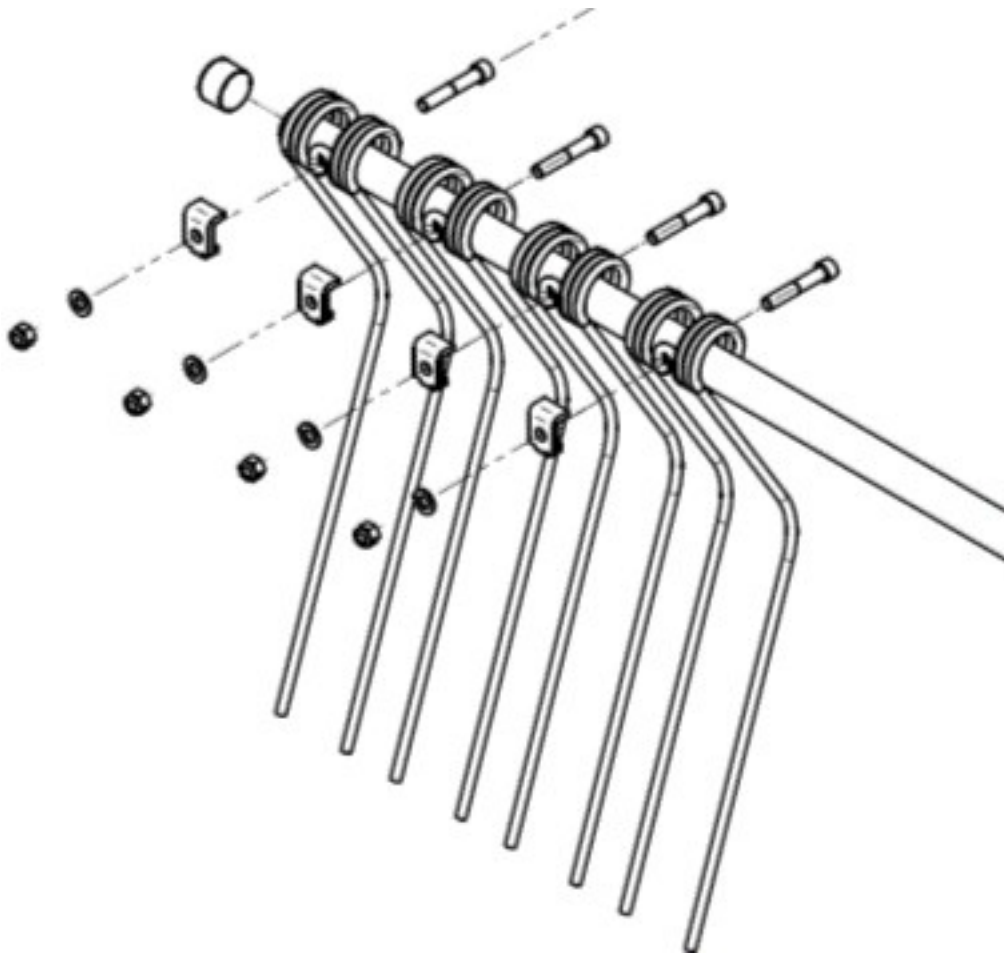

Fig. 14. Rake arm

Lubrication and Maintenance

7.2 Post-operation maintenance

Each time after work, the machine should be thoroughly cleaned, washed with a stream of running water and set on a flat, hard surface. Review the connections of parts and assemblies.

Replace damaged and worn parts with new ones. Check all bolted connections, and tighten loose ones according to “**Torque Specifications**” on page 40.

7.3 Lubricating the machine

Properly conducted periodic maintenance significantly reduces wear and tear on mating components and further protects against corrosion.

Lubricate all of the lubrication points listed below. These operations should be carried out using a grease gun for solid lubricants. Before starting lubrication, clean the lubrication area of dirt and residues of previously used grease and check the condition of the grease nipple for damage. If damage is found, replace with a working one. After lubrication, remove excess grease to reduce dust adhesion. In addition, there is SAE90EP oil in the mechanical transmission and only such oil should be used. The first oil change must be done after the first 50 hours worked. Subsequent replacements should be made after 400h of operation at least once a year before the season. There is a filler plug on the top body of the gearbox, which also serves as an oil level indicator. The drain plug is located at the bottom of the body. Check systematically before each use of the rake for oil leaks from the gearbox. If a leak is found, the leak must be repaired immediately and the oil refilled to the required volume. Repair of the gearbox during the warranty period can only be performed by specialized mechanical workshops.

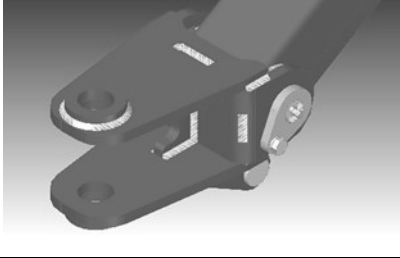
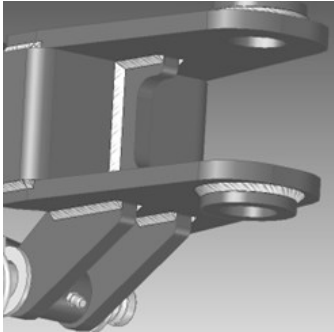
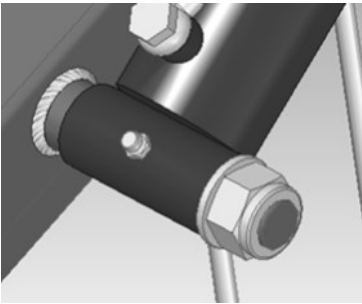
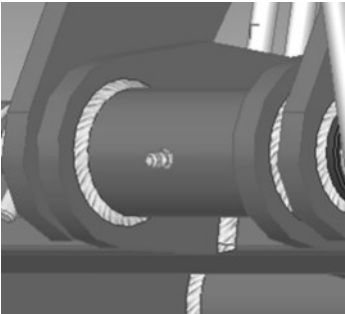
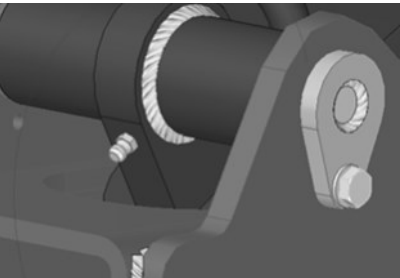

Lubrication and Maintenance

Lubrication and service intervals

Item	Lubrication Points	Description	Lubrication intervals	Type of lubricant
1		Hitch and beam connection pin	10 hours	Solid grease
2		Lower link bushing	10 hours	Solid grease
3		Beam cylinder bushing	30 hours	Solid grease
4		Chassis bushing	10 hours	Solid grease
5		Chassis cylinder eye	20 hours	Solid grease

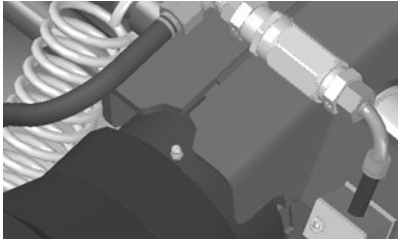
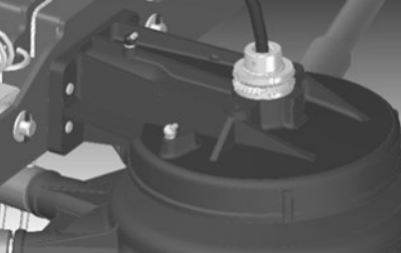

Lubrication and Maintenance

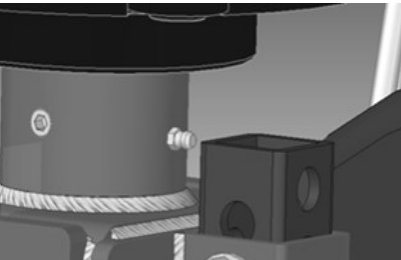
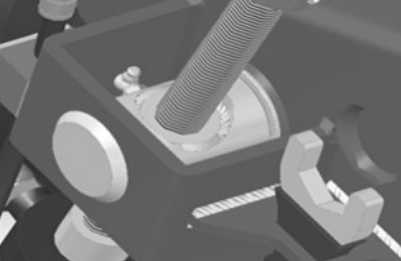
Lubrication and service intervals

Item	Lubrication Points	Description	Lubrication intervals	Type of lubricant
6		Drive shaft bearing support	10 hours	Solid grease
7		Mechanical transmission bearing	20 hours	Solid grease
8		Mechanical transmission oil chamber	400 hours - min. once a year	Oil SAE90EP TYP420- 5.7÷6dm ³ / TYP360- 2.8÷2.9dm ³
9		Main bushing	50 hours	Solid grease
10		Cylinder adjustment sleeve	30 hours	Solid grease

Lubrication and Maintenance

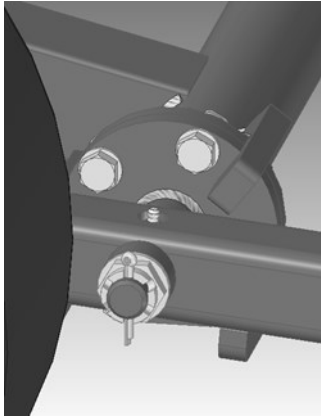
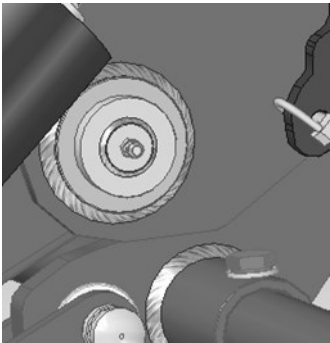
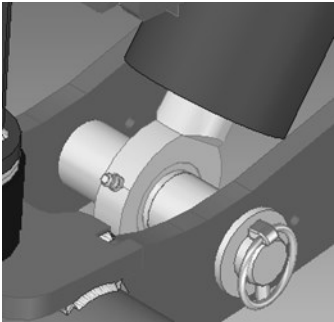
Lubrication and service intervals

Item	Lubrication Points	Description	Lubrication intervals	Type of lubricant
10		Tandem	20 hours	Solid grease
11		Pin connecting the main frame and intermediate beam	10 hours	Solid grease
12		Bottom eye of the chassis cylinder	20 hours	Solid grease
13		Articulated telescopic shaft	See PTO shaft manufactures manual for instructions.	Solid grease

Lubrication and Maintenance

7.4. Post-season maintenance

After work, the machine should be thoroughly cleaned and washed with a stream of running water. When using high-pressure generating equipment, be careful and do not direct the jet directly on any kind of stickers placed on the machine and on components such as bearings, shaft joints, etc. It is recommended that cleaning and washing of the machine be carried out in a car wash equipped with a sewage treatment plant or a settling tank for neutralization of the resulting sewage.

After washing and drying, inspect the general technical condition of all components and, if necessary, correct the defect found or replace the worn component with a new one. If the paint coating is damaged, mechanically remove the residue of the old paint, degrease then apply a coat of primer and after it dries apply the actual paint coating. It is recommended that the machine be stored in a closed and covered room to reduce environmental factors that cause corrosion and aging of any plastics. In addition, during long downtimes (such as the winter period), it is recommended to lubricate with fresh grease all moving joints and the pull screw of the rake height adjustment mechanism. In addition, using widely available silicone-based anti-corrosive agents, coat the surface of bolts and pins to inhibit corrosion. In addition, tires should be protected from UV rays about 2-3 times during the year by spraying widely available tire preservatives.

When not in use for a long period of time, move the machine slightly to reposition the tire so that it does not become permanently deformed, and additionally check the tire pressure. This activity should be carried out on average once per month.

Disassembly, Disposal, Environmental Protection

8. Disassembly, disposal and environmental protection

In the event the machine is worn to the extent which prevents its further use, it should be scrapped. This also applies to regular repairs and replacement of damaged parts. Clean the machine thoroughly before scrapping. Drain oil from the machine and have the machine decommissioned. Next, disassemble the machine by segregating its parts based on the applied materials. Segregated parts should be transported to a scrap yard or disposed of.

The machine is 100% environmentally friendly. 98% of the materials used in the production process are recyclable. Worn machine parts must be disposed of in line with the local environment protection regulations. Prevent oil leakage throughout the period of use of the machine, as oil may pollute the environment.

Caution: Protect hands (body) from mutilation and harmful effects of lubricants and oils. Use personal protective equipment and tools in good working condition. Machine components that may move or rotate during disassembly should be properly secured.

Worn or damaged parts removed during repair (disassembly) should be stored in a separate location, with a limited access for persons and animals. Worn out metal parts must be delivered to the scrap metal collection points. Worn out plastics must be delivered to the chemical waste collection (utilization) points.

When filling up or replacing the oil, avoid its spillage. Store the waste oil in sealed containers, and periodically deliver it to the special collection (utilization) points.



Abandoned machine parts or components, spilled oil can create accident hazards and cause environmental pollution and violate applicable regulations.

PTO Driveline Instructions

Instructions for Installing a PTO Driveline:

1. Begin by parking the tractor and implement on a level, solid surface. Attach the implement to the tractor's hitch arms, upper and lower. Adjust the tractor's 3-point hitch so that the tractor's output shaft is level with the implement's input shaft.
2. Leave the tractor in gear, shut off the tractor engine, remove the key and set the park brake. Block the implement to prevent it from falling over or shifting.
3. Slide the inner yoke of the PTO shaft 'A' (implement end) onto the input shaft of the implement. Make sure the yoke is securely locked in place.
4. Slide the outer yoke of the PTO shaft 'B' (tractor end) onto the tractor input shaft. Make sure the yoke is securely locked in place.
5. Because of differences in tractor 3-point arms and implements, it may be necessary to shorten the PTO Driveline. See next page for **"Instructions for Shortening a PTO Driveline"**.
6. Check that the PTO Driveline yokes are securely attached to the tractor and implement before operating. PTO Drivelines not attached properly can cause serious injury or death!
7. If your PTO Driveline shields are equipped with chains, secure the chain to the tractor and or implement to prevent the shield from rotating.
8. Before starting tractor and engaging the PTO Driveline, make certain there are no people or animals between tractor and implement. Rotating PTO Drivelines can cause serious injury or death!

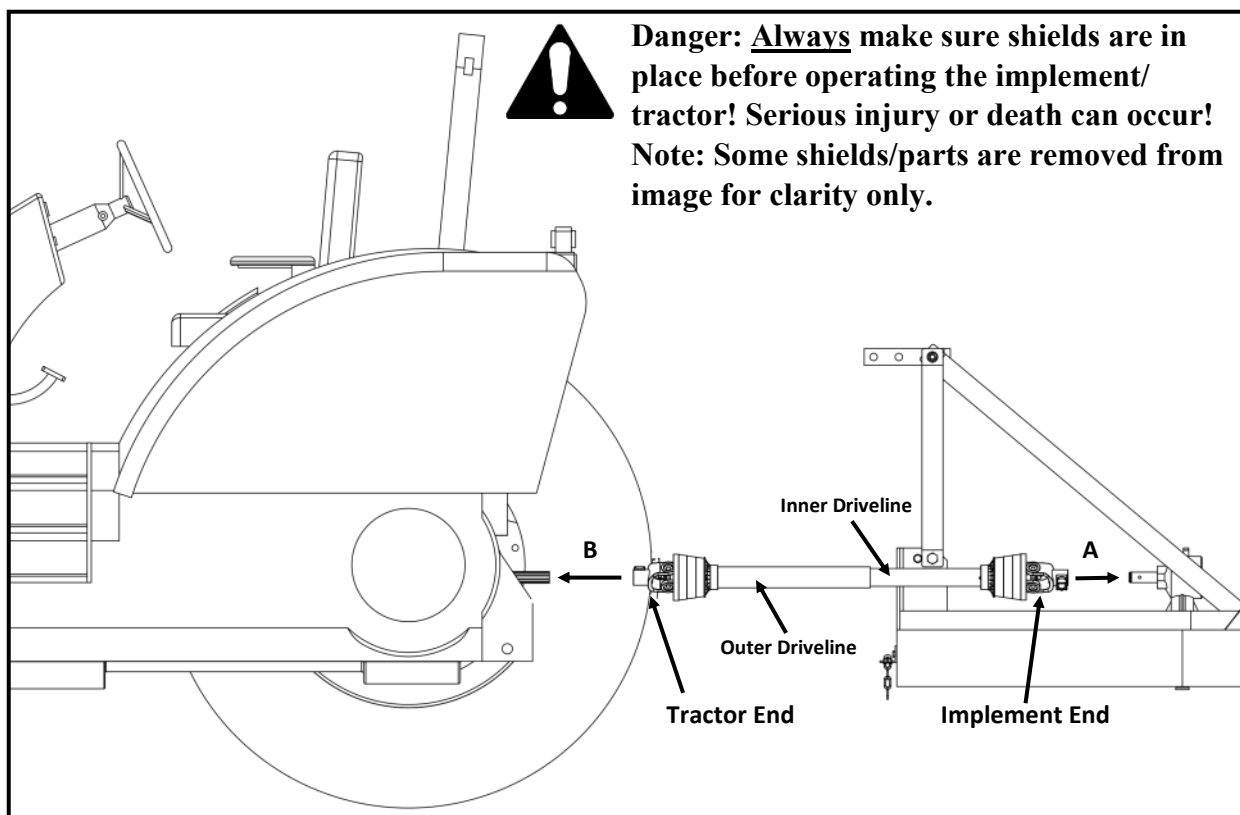

PTO Driveline Instructions

Instructions for Shortening a PTO Driveline:

 **Note:** If you are not confident modifying the PTO Driveline, you should contact a Qualified Professional.

1. Separate the inner and outer PTO Drivelines. Leave separated at this time.
2. Attach the outer PTO Driveline to the tractor implement input shaft and inner PTO driveline to the implement input shaft.
3. With the drivelines parallel to one another, measure 1" (dim. 'B') back from the outer PTO Driveline shield (see fig. 2) and make a mark on the inner PTO Driveline.
4. Measure 1" (dim 'B') back from the inner PTO Driveline shield (see fig. 2) and make a mark on the outer PTO Driveline.
5. Remove the drivelines from the tractor and implement.
6. Measure from the end of the inner shield to the scribed mark (dim. "C"). Cut the inner shield at that mark. Cut the same amount off the inner shaft (dim. "C1").
7. Measure from the end of the outer shield to the scribed mark (dim. "D"). Cut the outer shield at that mark. Cut the same amount off the inner shaft (dim. "D1").
8. Clean off all burrs from both drivelines.
9. Refer to "Checking PTO Driveline Extended Length" section next.

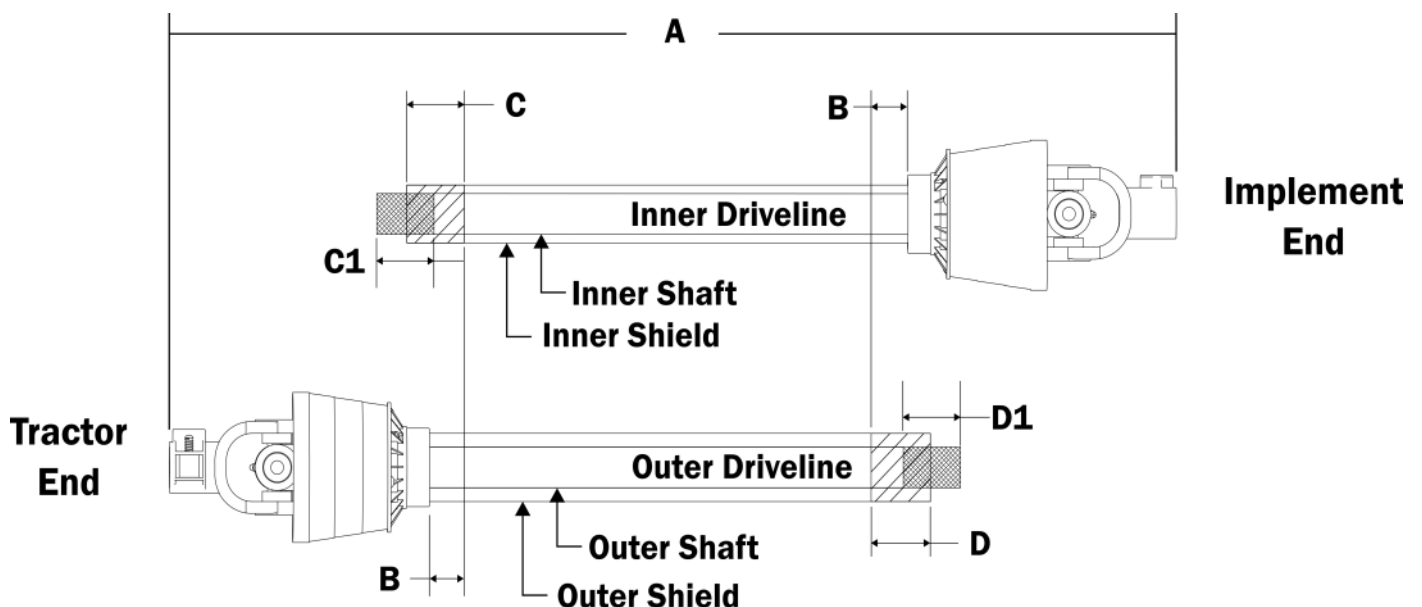

PTO Driveline Instructions

Checking PTO Driveline Extended Length:

1. Apply multi-purpose grease to the outside of the inner driveline section. Assemble the outer and inner drivelines.
2. When fully extended, the maximum allowable length must have a minimum overlap of $\frac{1}{3}$ the free length of the inner and outer sections. Measure and record the maximum extended length for future reference.
3. Attach the outer PTO Driveline to the tractor implement input shaft and inner PTO driveline to the implement input shaft.
4. Pull both yoke ends to make sure they are properly seated on the input shafts. **Warning:** If the drive lines are not properly seated, they can separate from the tractor or implement, causing extensive damage and possibly serious injury or death.
5. Raise and lower the implement to determine the maximum extended length. Make sure the maximum extended length does not exceed the maximum length determined from step 2.

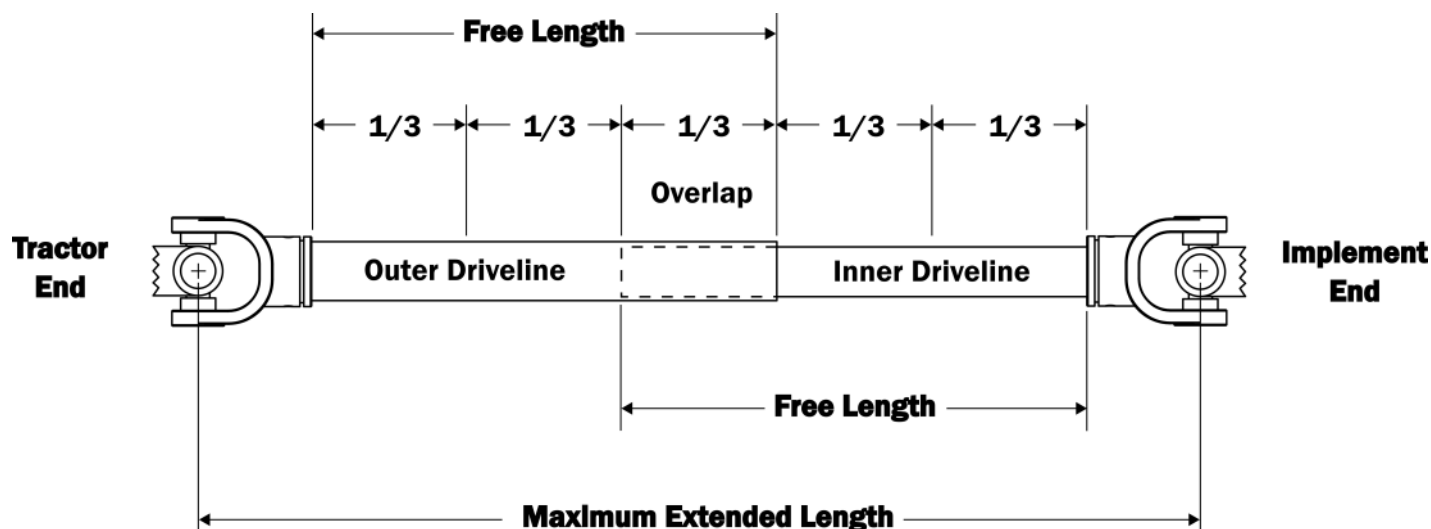

Danger: Always make sure shields are in place before operating the implement/tractor! Serious injury or death can occur!

Note: Some shields/parts are removed from image for clarity

PTO Driveline Instructions

Checking for PTO Driveline Interference:

1. Begin with the PTO Driveline level (0 degrees). Raise the implement at an angle no greater than 25 degrees from level. Check for any interference and the length of the PTO Driveline extended. Do not exceed the maximum extended length!
2. Next lower the PTO Driveline at an angle no greater than 25 degrees from level. Check for any interference and the length of the PTO Driveline extended. Do not exceed the maximum extended length!

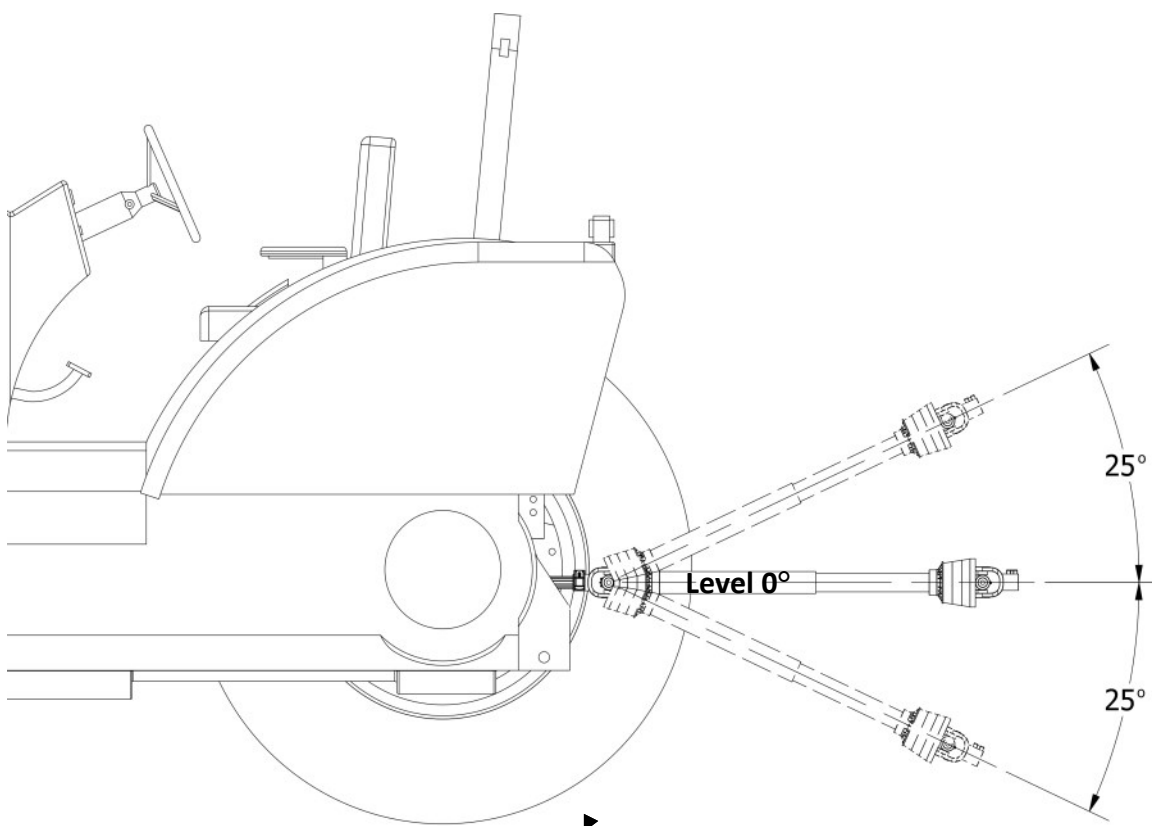

Danger: Always make sure shields are in place before operating the implement/tractor! Serious injury or death can occur!

Note: Some shields/parts are removed from image for clarity



Scan the QR code below for more detailed information on PTO installation.



Torque Specifications

Torque Specifications for Common Bolt Sizes															
Inches		Bolt Head Identification						Metric		Bolt Head Identification					
										5.8		8.8		10.9	
		Grade 2		Grade 5		Grade 8		Class 5.8		Class 8.8		Class 10.9			
Bolt size (inches)	Thread pitch	N.m	ft-lb	N.m	ft-lb	N.m	ft-lb	Bolt size (metric)	Thread pitch	N.m	ft-lb	N.m	ft-lb	N.m	ft-lb
1/4"	20	7	5	11	8	16	12	M5	0.08	4	3	6	4	9	7
1/4"	28	8	6	13	10	19	14	M6	1	6	4	10	7	15	11
5/16"	18	15	11	24	17	33	25	M8	1.25	16	12	25	18	36	27
5/16"	24	17	13	26	19	37	27	M8	1	17	13	26	19	38	28
3/8"	16	27	20	42	31	59	44	M10	1.5	31	23	48	35	71	52
3/8"	24	31	23	47	35	67	49	M10	1.25	33	24	51	38	75	55
7/16"	14	43	32	67	49	95	70	M10	1	35	26	53	39	78	58
7/16"	20	48	36	75	55	106	78	M12	1.75	54	40	84	62	123	91
1/2"	13	66	48	102	75	144	106	M12	1.5	56	41	87	64	128	94
1/2"	20	75	55	115	85	163	120	M12	1.25	59	44	90	66	133	98
9/16"	12	95	70	147	109	208	154	M14	2	84	62	133	98	195	144
9/16"	18	106	79	164	121	232	171	M14	1.5	94	69	142	105	209	154
5/8"	11	132	97	203	150	287	212	M16	2	131	97	206	152	302	223
5/8"	18	149	110	230	170	325	240	M16	1.5	141	104	218	161	320	236
3/4"	10	233	172	361	266	509	376	M18	2.5	181	133	295	218	421	310
3/4"	16	261	192	403	297	569	420	M18	2	196	145	311	229	443	327
7/8"	9	226	167	582	430	822	606	M18	1.5	203	150	327	241	465	343
7/8"	14	249	184	642	473	906	668	M20	2.5	256	189	415	306	592	437
1"	8	339	250	873	644	1232	909	M20	1.5	288	212	454	335	646	476
1"	12	371	273	955	704	1348	995	M22	2.5	344	254	567	418	807	595
1-1/8"	7	480	354	1077	794	1746	1288	M22	1.5	381	281	613	452	873	644
1-1/8"	12	539	397	1208	891	1958	1445	M24	3	444	327	714	526	1017	750
1-1/4"	7	677	500	1519	1120	2463	1817	M24	2	488	360	769	567	1095	808
1-1/4"	12	750	553	1682	1241	2728	2012	M27	3	656	484	1050	774	1496	1103
1-3/8"	6	888	655	1992	1469	3230	2382	M27	2	719	530	1119	825	1594	1176
1-3/8"	12	1011	746	2268	1673	3677	2712	M30	3.5	906	668	1420	1047	2033	1499
1-1/2"	6	1179	869	2643	1949	4286	3161	M30	2	1000	738	1600	1180	2250	1659
1-1/2"	12	1326	978	2974	2194	4823	3557	M36	4	1534	1131	2482	1830	3535	2607

Notes:

This chart is an approximate estimate of torque values.

Always tighten hardware to these values unless a different torque value or tightening procedure is listed for a specific application.

Fasteners must always be replaced with the same grade as specified in the manual.

Always use the proper tool for tightening hardware: SAE for SAE hardware and Metric for Metric hardware.



Rotary Rake

ZGR-420



Parts Manual

Rel. 09/24

Main Hitch

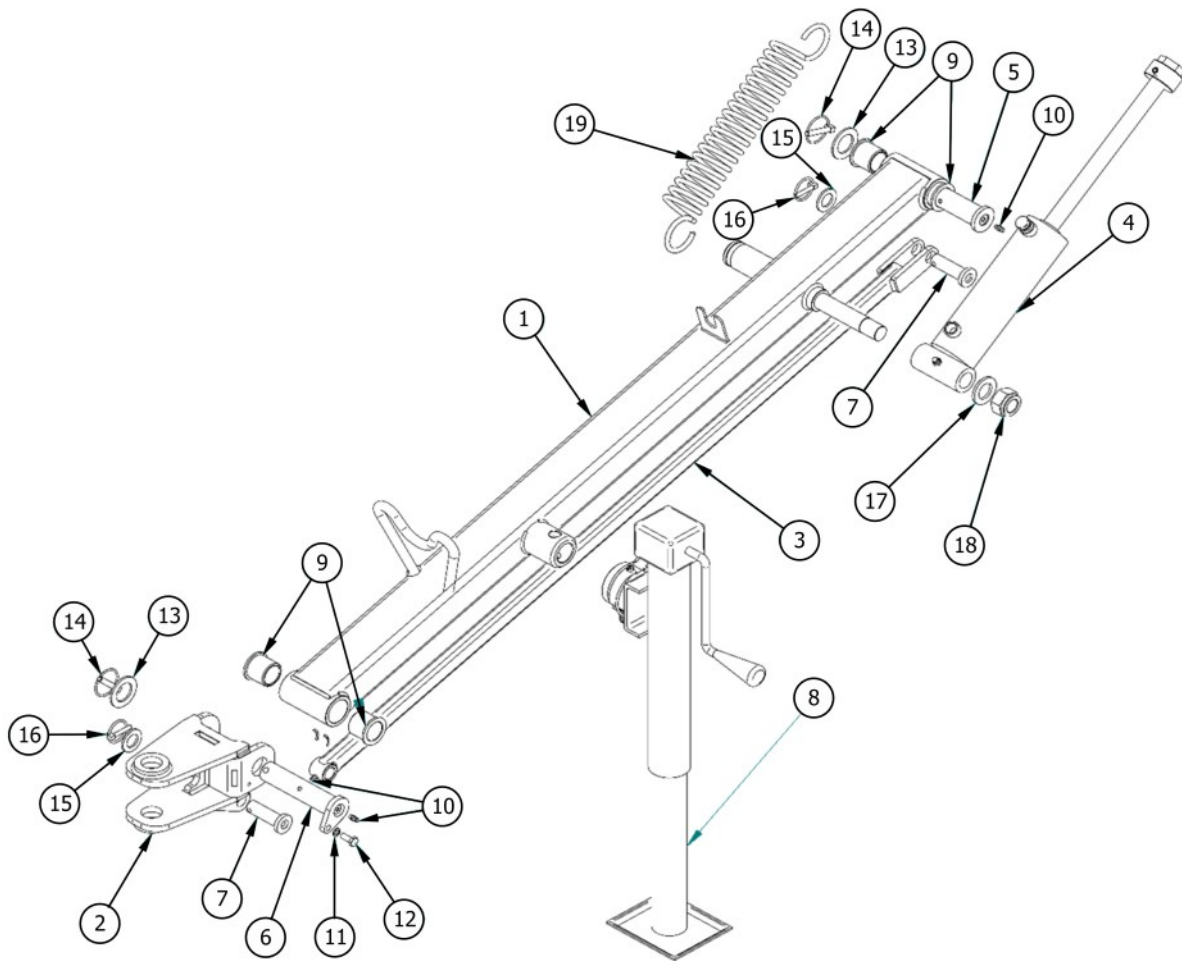

Main Hitch

Item	Part #	Description	Qty.
1	ZGR10003	Intermediate beam	1
2	ZGR10004	Welded hitch	1
3	ZGR10005	Hitch link	1
4	ZGR10027	Hitch cylinder	1
5	ZGR10022	Frame connector pin	1
6	ZGR10017	Hitch pin	1
7	ZGR10026	Link pin	2
8	ZGR10186	Support foot	1
9	ZGR10174	Joint bushing	4
10	GN061S	Grease nipple M6x1 DIN 71412-A	3
11	LW08	Spring washer M8 OC DIN 7980	1
12	BM08125	Screw M8x20 OC 8.8 DIN 933	1
13	FW30	M30 DIN 125 plain washer	2
14	ZGR10095	OC folding pin 8mm	2
15	FW20	M20 plain washer	2
16	ZGR10170	OC folding pin 6mm	2
17	ZGR10130	M25 OC plain washer	2
18	LN24	Self-locking nut M24 DIN 985	1
19	ZGR10147	Tension spring	12

Driveline

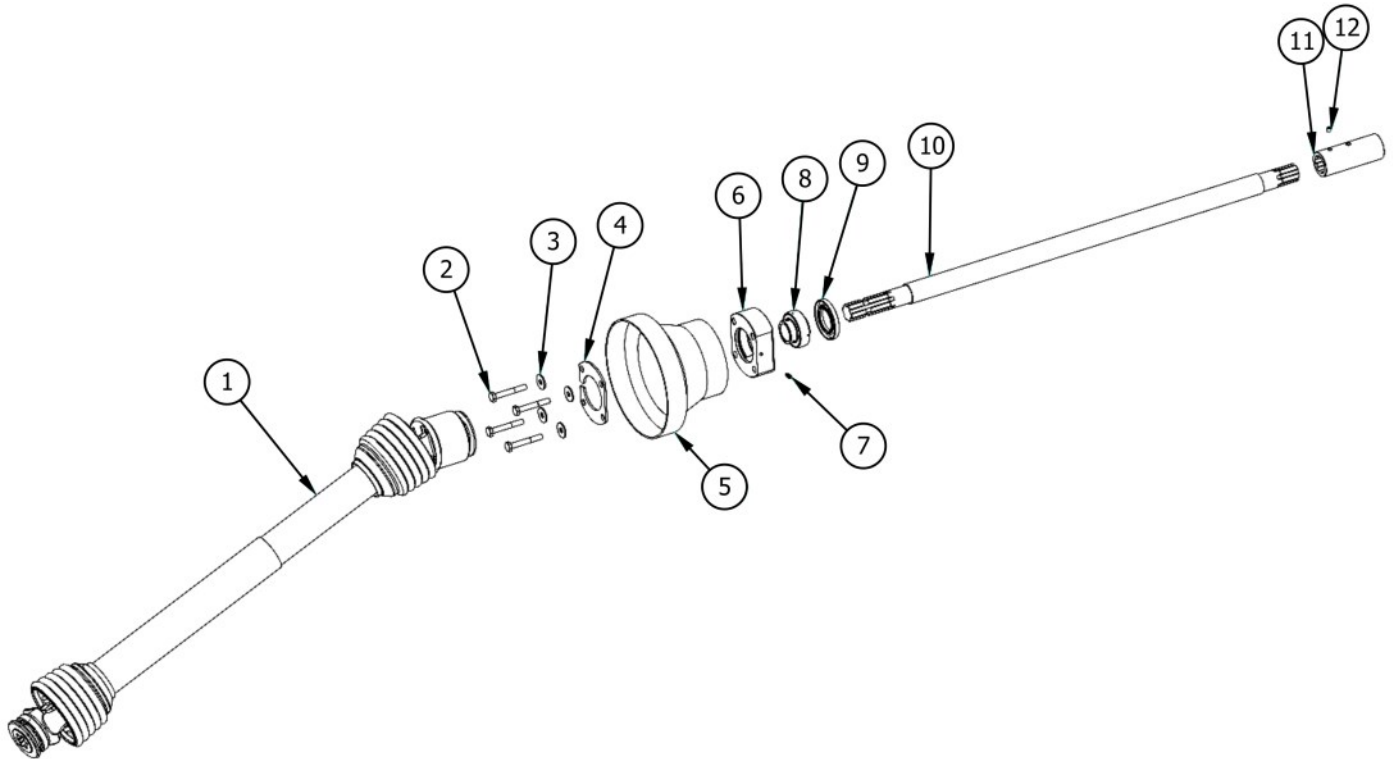

Item	Part #	Description	Qty.
1	ZGR10177	Power take-off	1
2	BM101570	Screw M10x70-8.8 OC DIN 931	4
3	FW10	M10 OC DIN 9021 enlarged washer	4
4	ZGR10044	PTO shield mounting plate	1
5	ZGR10115	PTO cover	2
6	ZGR10085	Bearing housing	1
7	GN061S	Grease nipple M6x1 DIN 71412-A	1
8	BUC207	UC 207 bearing	1
9	ZGR10165	Sealer 48x80x10	2
10	ZGR10024	Drive shaft	1
11	ZGR10046	Drive shaft connector	4
12	ZGR10167	Pressure screw M8x8 DIN 913	1

Hydraulic System

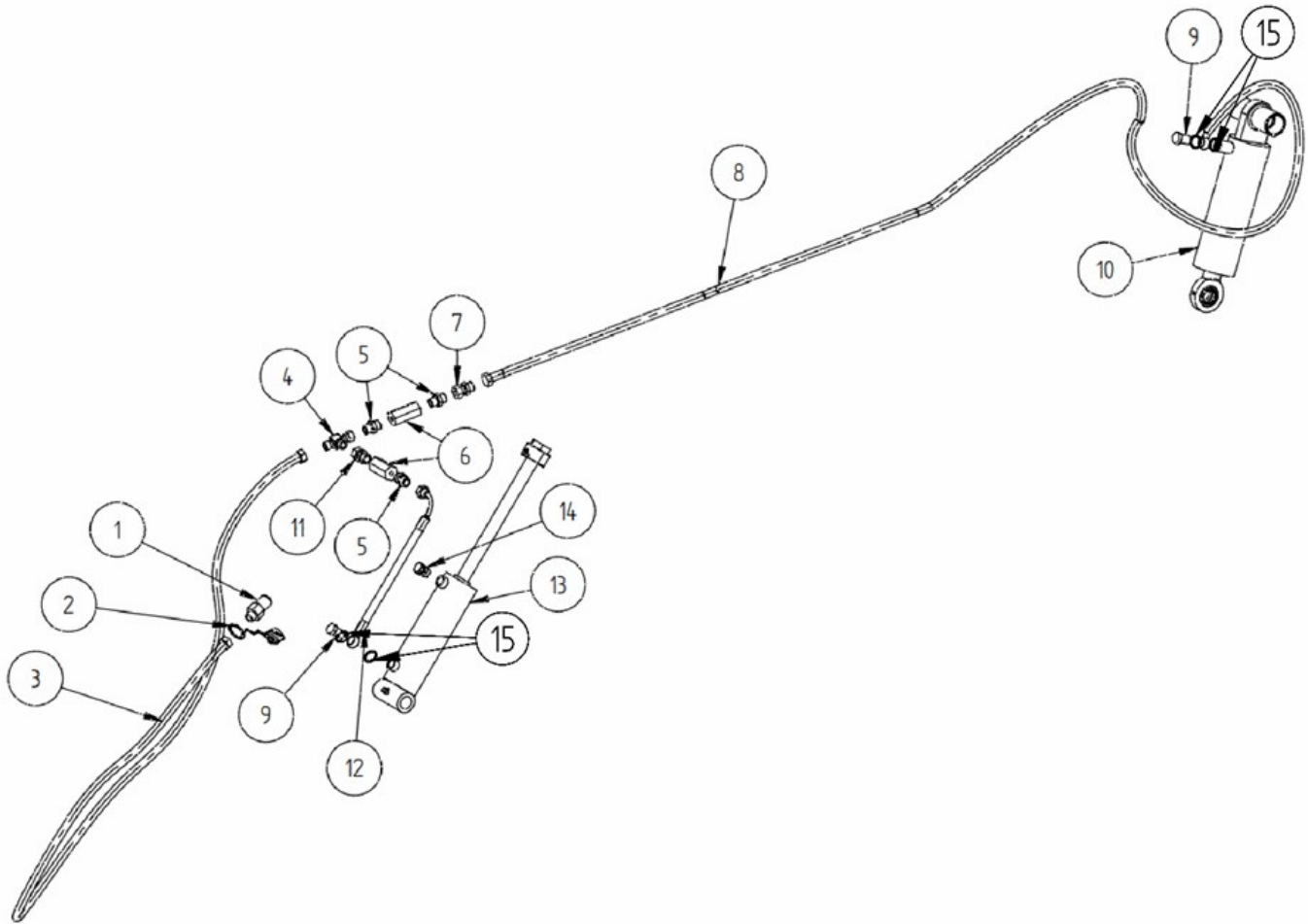

Item	Part #	Description	Qty.
1	ZGR10173	ISO mushroom coupling M18x1.5	1
2	ZGR10135	Plug cover	1
3	ZGR10192	Cable P51/P51 M18x1.5/M18x1.5 1SN DN8 L-2200	2
4	ZGR10182	BAB tee connector M18x1.5	1
5	ZGR10139	Straight connection G3/8 M18x1.5	4
6	ZGR10187	3/8" throttling valve	2
7	ZGR10188	Straight fitting AA M18x1.5/M16x1.5	2
8	ZGR10194	WIRE P01/P21 fi18/M16x1.5 1SN DN8 L-3000	2
9	ZGR10189	Overflow screw M18x1.5	2
10	ZGR10142	Axle height adjustment cylinder	1
11	ZGR10138	Straight connection AB M18x1.5 / G3/8"	1
12	ZGR10193	WIRE P01/P52 fi18/M18x1.5 1SN DN8 L-400	2
13	ZGR10141	Hitch cylinder	1
14	ZGR10191	Vent M18x1.5	1
15	ZGR10190	M18 copper washer	4

Main Frame

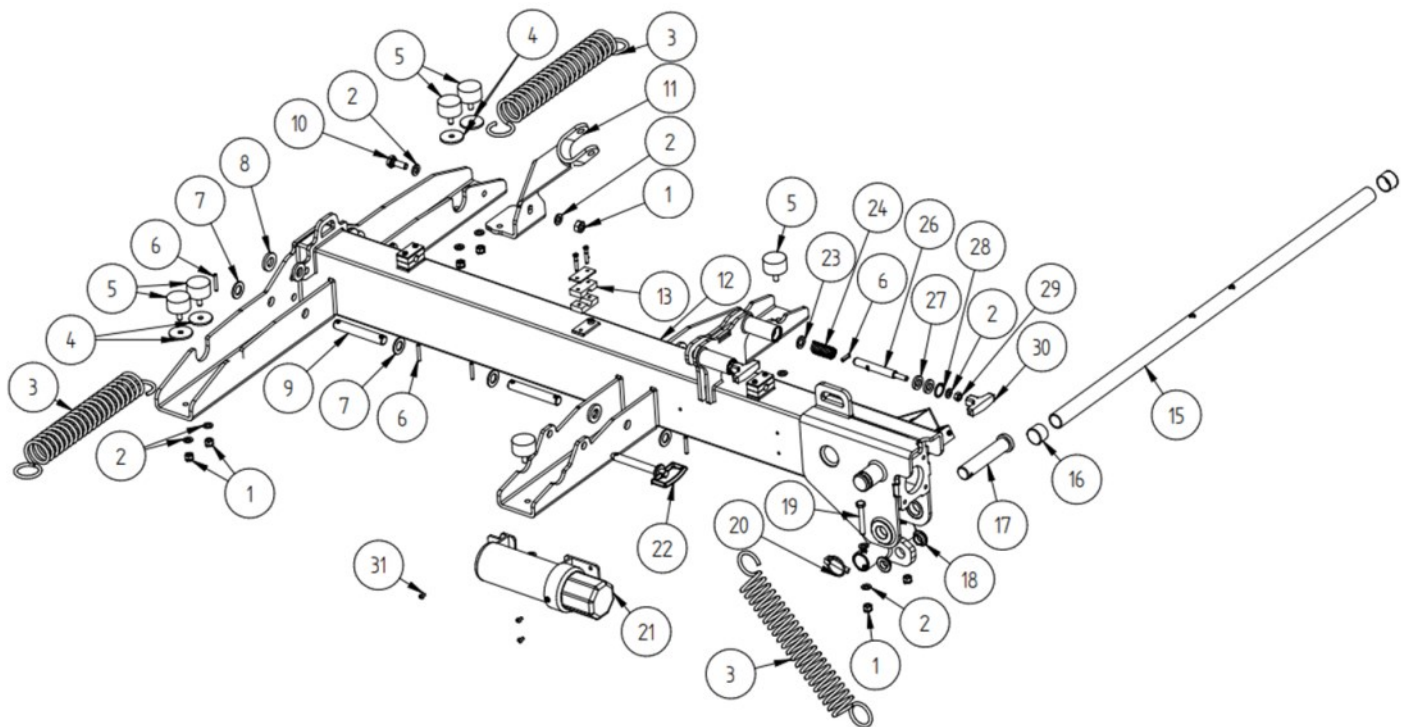

Main Frame

Item	Part #	Description	Qty.
1	LNM1015	Self-locking nut M10 OC DIN 985	9
2	FW10	M10 OC DIN 125 plain washer	13
3	ZGR10147	Tension spring	3
4	ZGR10063	OC rubber bumper washer	4
5	ZGR10163	Vibration damper type D 5028.D70	6
6	ZGR10093	Spring pin 6x40 DIN 1481	10
7	FW20	M20 OC DIN 125 plain washer	8
8	ZGR10062	Shield arm spacer	8
9	ZGR10039	Shield arm pin	4
10	BM101535	Screw M10x35 OC 8.8 DIN 933	1
11	ZGR10064	Arm rotation lock	1
12	ZGR10002	Welded frame	1
13	ZGR10112	Wire clamp 15mm cpl.	3
15	ZGR10016	Central cover	1
16	ZGR10134	Pipe cover	2
17	ZGR10022	Frame connection pin	1
18	ZGR10021	Link bushing	2
19	BM101570	Screw M10x70 OC 8.8 DIN 931	2
20	ZGR10153	OC folding pin 8mm	1
21	ZGR10133	Document container	1
22	ZGR10185	Pin with handle	1
23	ZGR10043	Bolt washer 1	1
24	ZGR10146	Compression spring Ø25 L70Ø2 80.005.044	2
26	ZGR10041	Bolt pin	2
27	ZGR10042	Bolt washer 2	4
28	SRI-30	W30 circlip	2
29	LNM1015	Nut M10 OC 8 DIN 934	2
30	ZGR10164	Handle intern. thr. M10	2
31	ZGR10178	Farmers screw 4.8x25	3

Protective Barriers

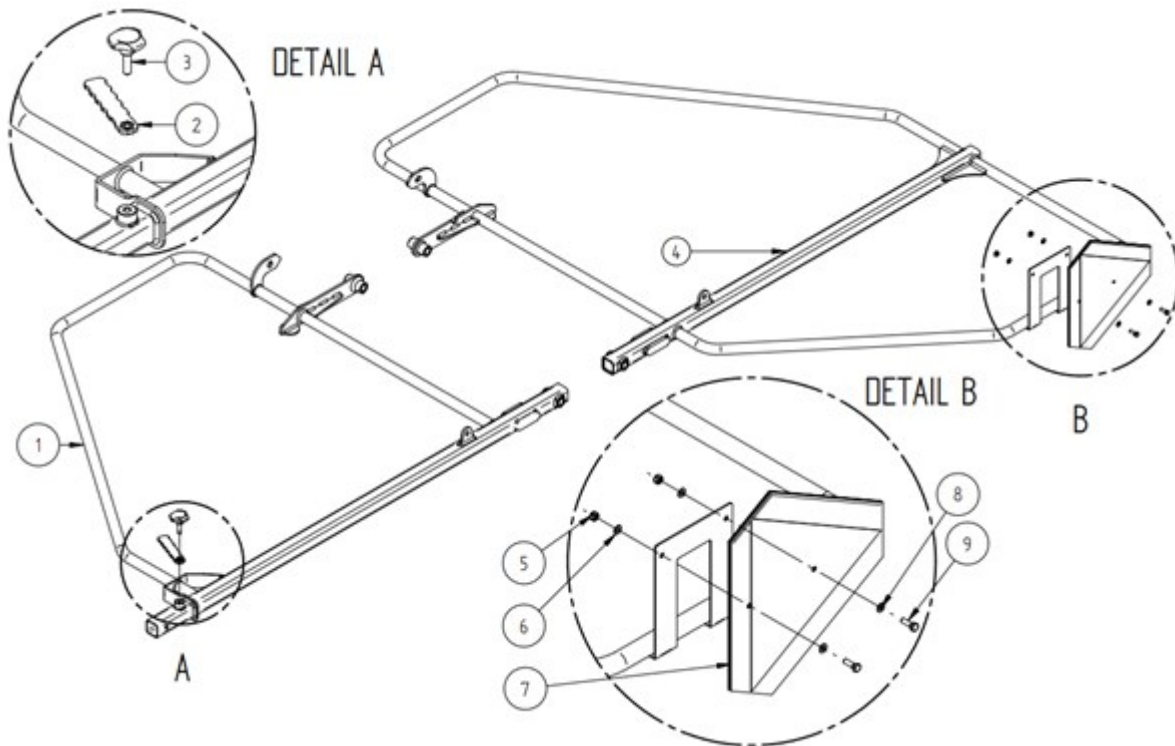

Protective Barriers

Item	Part #	Description	Qty.
1	ZRG10012	Safety barrier-side of the swath	1
2	ZGR10001	Counter lever	1
3	ZGR10184	Cross knob	4
4	ZGR10013	Safety barrier-side of the identification plate	1
5	LN08125	Self-locking nut M8 OC DIN 985	2
6	FW08	Plain washer M8 OC DIN 125	2
7	ZGR10158	Identification plate	1
8	LFW08	Enlarged washer M8 OC DIN 9021	2
9	BM0812520	Screw M8x20 OC 8.8 DIN 933	2

Gearbox

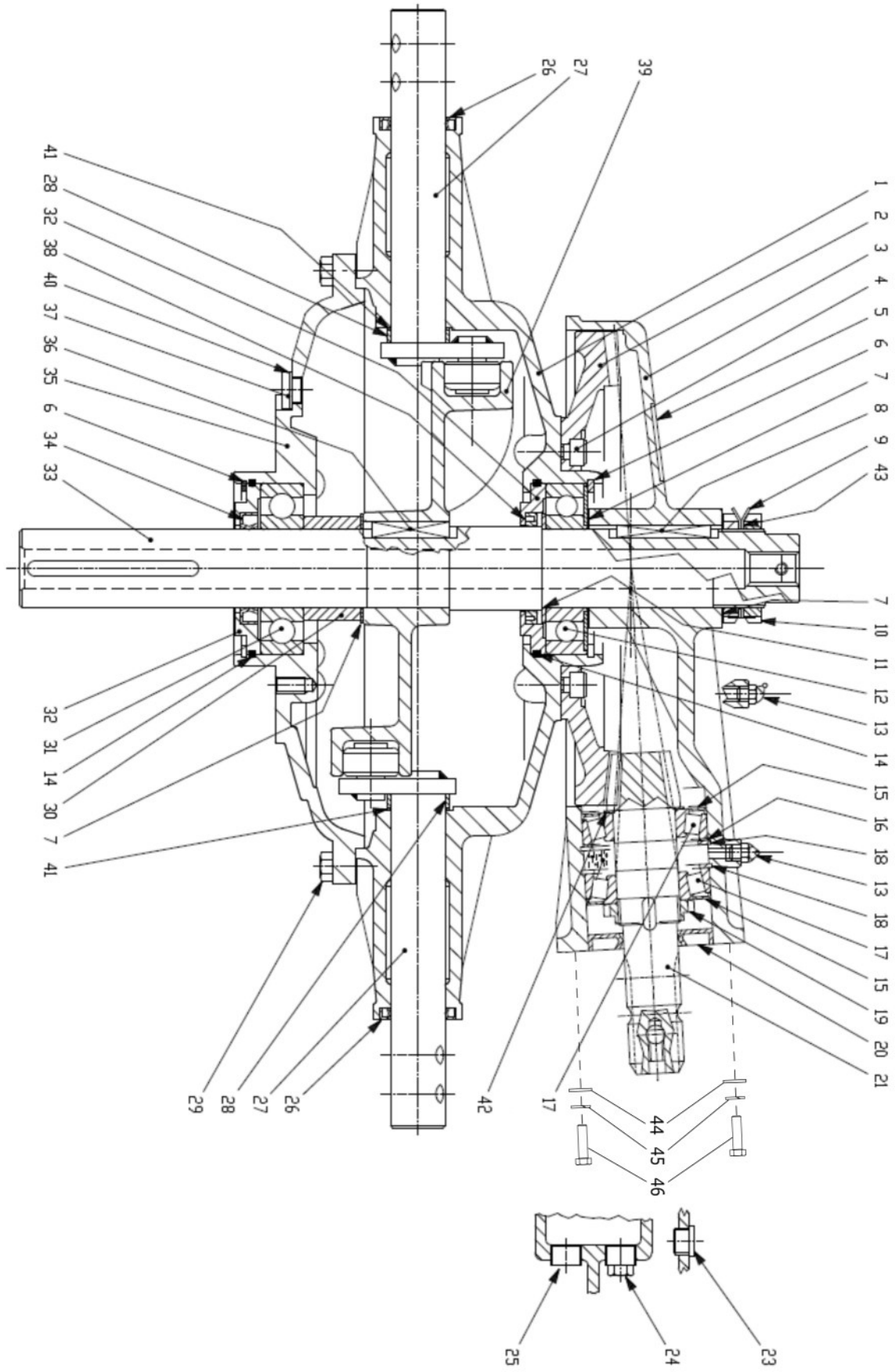

Gearbox

Item	Part #	Description	Qty.
1	ZGR10195	Casing - gearbox, ZGR-420	1
2	ZGR10196	Crown wheel Z82 M3.75	1
3	ZGR10197	Cover - gearbox, ZGR-420	1
4	ZGR10198	Bolt M10x22 8.8	8
5	ZGR10199	Plate - gearbox, ZGR-420	1
6	ZGR10200	Snap ring 110UNI7437	2
7	ZGR10201	Shim 70.3	3
8	ZGR10202	Parallel key B 10X8X60	1
9	ZGR10203	Spring washer 50x74x1.25	2
10	ZGR10204	Locknut 50X1,5 H11	2
11	ZGR10205	Shim 50.3x2.5	1
12	ZGR10206	Bearing 6310 Z	1
13	ZGR10207	Grease nipple 45G.M10X1	2
14	ZGR10208	O-ring 101,27X2,62	2
15	ZGR10209	Protective washer 30208 AV	2
16	ZGR10210	Shim 79.9	1
17	ZGR10211	Bearing 30208	2
18	ZGR10212	Snap ring 80 UNI7437	2
19	ZGR10213	Nut M40X1.5	1
20	ZGR10214	Oil seal 35X80X10	1
21	ZGR10215	Pinion shaft Z10 M3.75	1
22			
23	ZGR10216	Plug 3/8" gas	1
24	ZGR10217	Plug 1/2" gas	1
25	ZGR10218	Plug 1/2" gas	1
26	ZGR10219	Oil seal 35X45X7	11
27	ZGR10220	Connecting rod - gearbox, ZGR-420	11
28	ZGR10221	Spacer	11
29	ZGR10222	Bolt M10x30 8.8	11
30	ZGR10223	Spacer	1
31	ZGR10224	Bearing 6310	1
32	ZGR10225	Cover - gearbox, ZGR-420	2
33	ZGR10226	Shaft - gearbox, ZGR-420	1
34	ZGR10227	Oil seal 50X72X8	1
35	ZGR10228	Cover - gearbox, ZGR-420	1
36	ZGR10229	Parallel key B 10X8X50	1
37	ZGR10230	Oil drain plug 3/8"GAS	1
38	ZGR10231	Double lip seal 55X72X10	1
39	ZGR10232	Camme - gearbox, ZGR-420	1

Gearbox

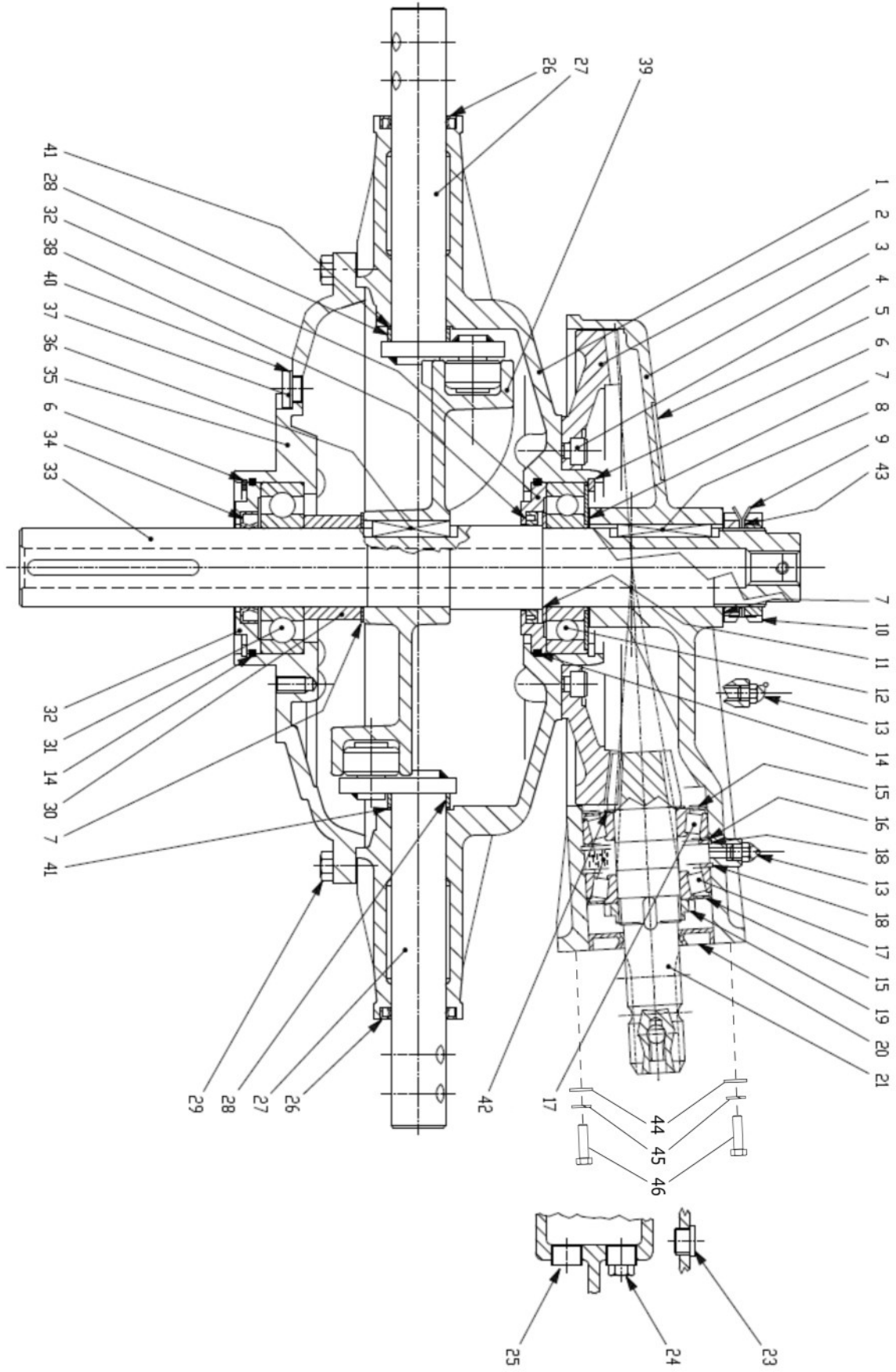

Gearbox

Item	Part #	Description	Qty.
40	ZGR10233	Bolt washer 17x22x1.5	1
41	ZGR10234	Shim 35.2x43.8x1	11
42	ZGR10135	Shim 40.3x1.0	1
43	ZGR10136	Shim 2x57.5x0.5	1
44	FW14	Plain washer M14 OC DIN 125	4
45	LW14	Spring washer M14 OC DIN 7980	4
46	BM142035	Bolt M14x35-8.8 OC DIN 933	4
-	ZGR10137	11 arm gearbox, ZGR-420	1

Rake Arm Folding

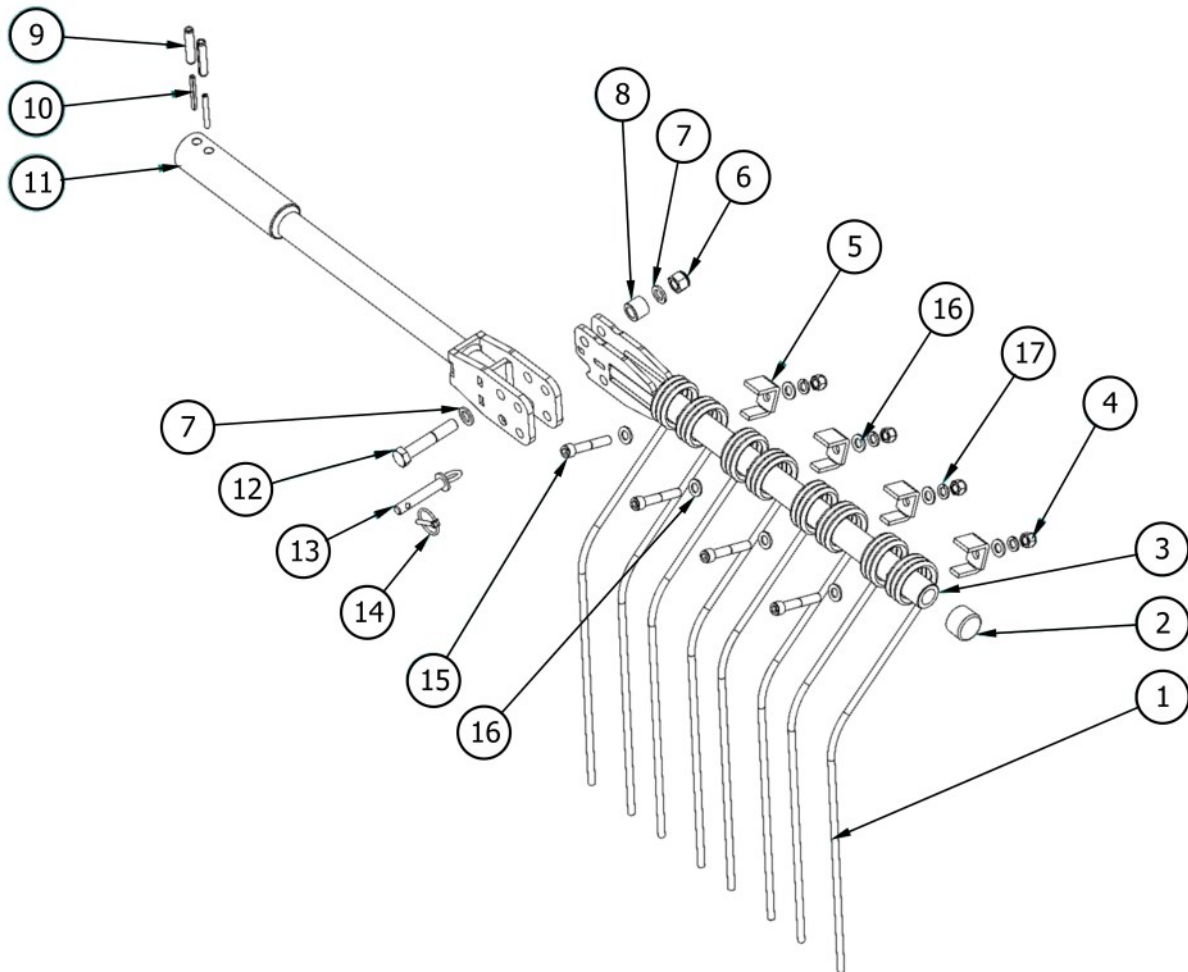

Item	Part #	Description	Qty.
1	ZGR10117	Tine	24
2	ZGR10183	Pipe cap	6
3	ZGR10058	Folding arm - raking section	6
4	LNM12175	Self-locking nut M12 OC DIN 985	24
5	ZGR10057	Oc rake finger attachment	24
6	LNM1620	Self-locking nut M16 OC DIN 985	6
7	FW16	Plain washer M16 OC DIN 125	6
8	ZGR10060	Arm spacer	1
9	ZGR10090	Spring pin 12x60 DIN 1481	12
10	ZGR10092	Spring pin 7x60 DIN 1481	12
11	ZGR10059	Folding arm transmission section	6
12	BM162090	Screw M16x90-8.8 OC DIN 931	6
13	ZGR10061	Pin for locking folding arms	6
14	ZGR10170	Pin OC 6mm	6
15	BM1217580PT	Screw M12-1.75x80-8.8 partial thread	4
16	ZGR10125	Plain washer M12 OC DIN 125	24
17	ZGR10120	Spring washer M12 OC DIN 7980	24

Rigid Rake Arm

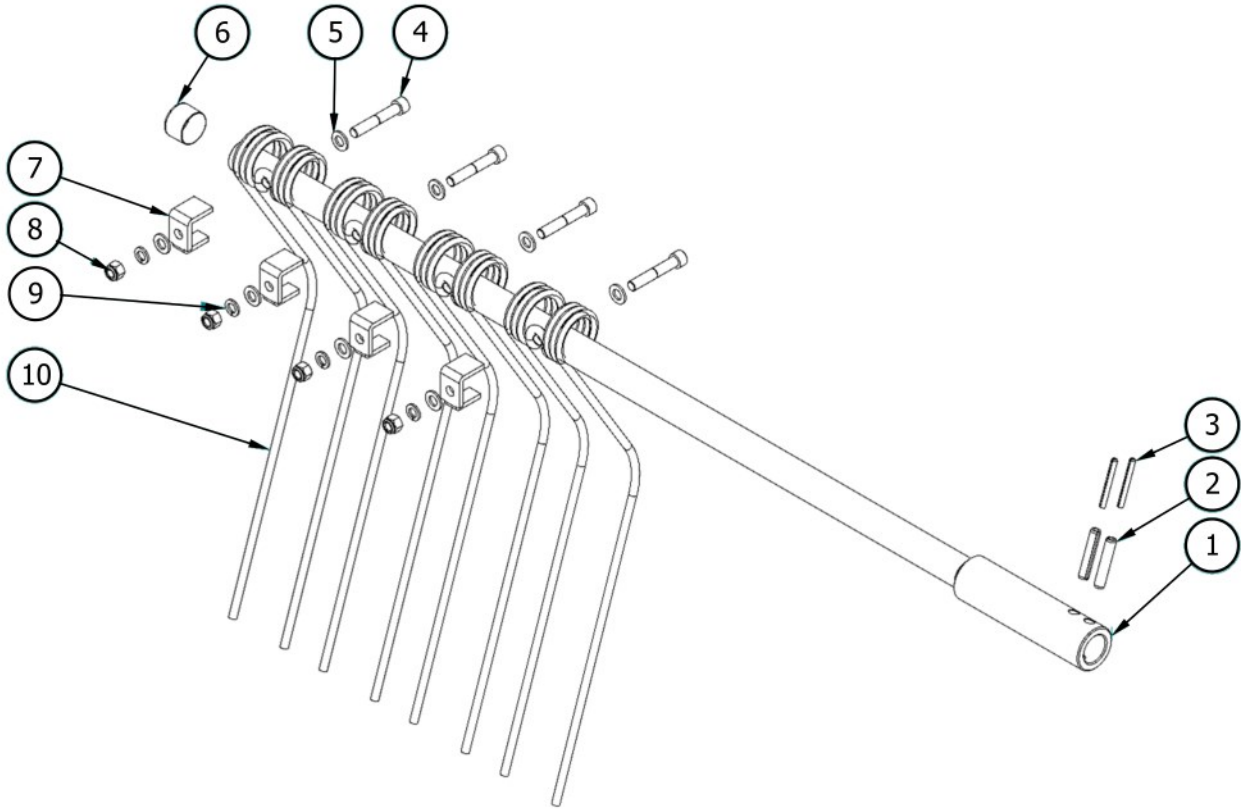

Item	Part #	Description	Qty.
1	ZGR10056	Fixed arm	5
2	ZGR10090	Spring pin 12x60 DIN 1481	10
3	ZGR10092	Spring pin 7x60 DIN 1481	10
4	BM1217580PT	Screw M12-1.75x80-8.8 partial thread	20
5	FW12	Plain washer M12 OC DIN 125	40
6	ZGR10183	Pipe cap	5
7	ZGR10057	Rake finger attachment	20
8	LNM12175	Self-locking nut M12 OC DIN 985	20
9	LW12	Spring washer M12 OC DIN 7980	20
10	ZGR10117	Rake finger	20

Chassis

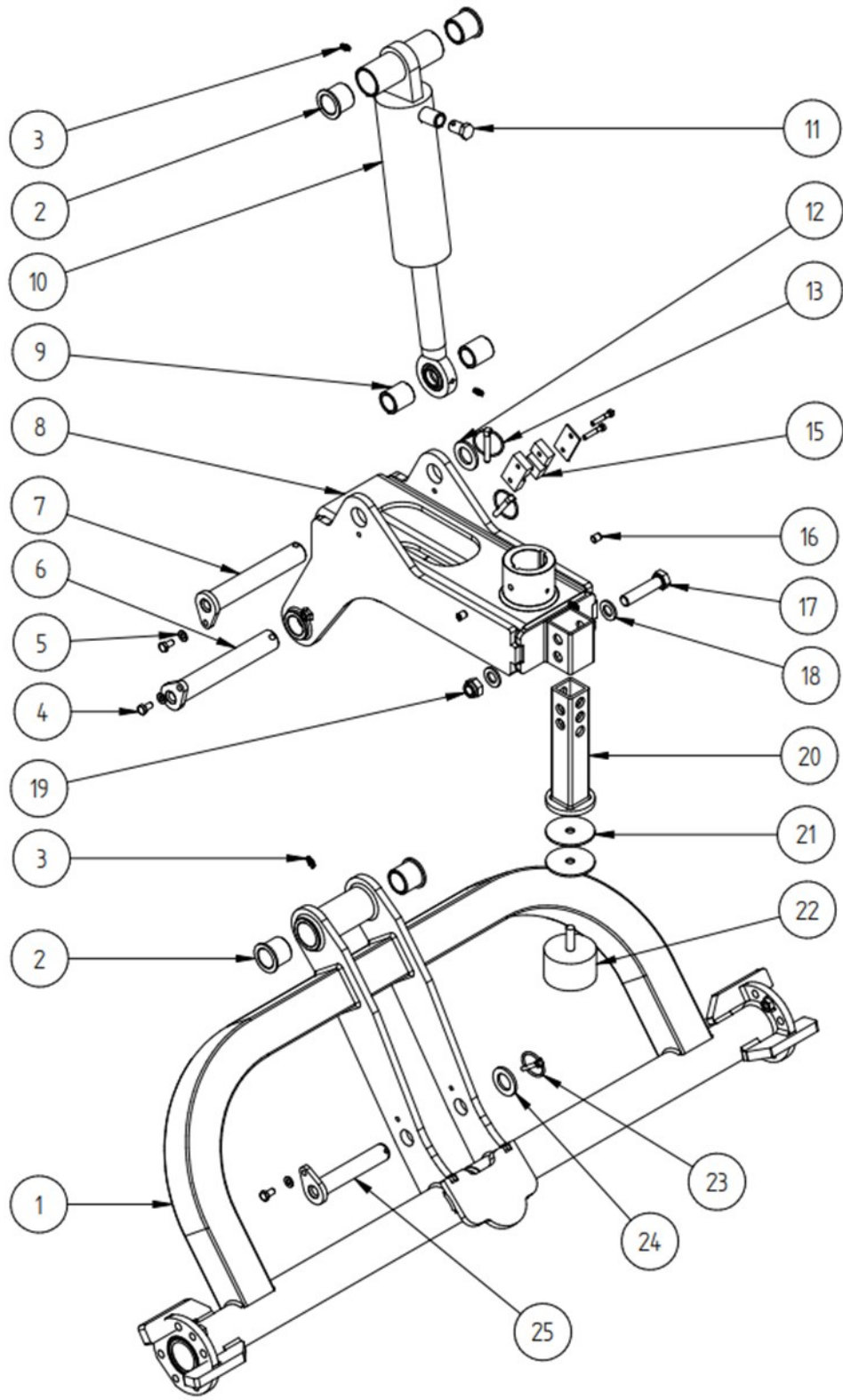

Chassis

Item	Part #	Description	Qty.
1	ZGR10007	Wheel axle frame	1
2	ZGR10174	Joint bushing	4
3	GN0615	Grease nipple M6x1 DIN 71412-A	3
4	BM0812516	Screw M8x16 OC 8.8 DIN 933	3
5	LW08	Spring washer M8 OC DIN 7980	3
6	ZGR10020	Chassis hinge pin	1
7	ZGR10025	Cylinder pin	1
8	ZGR10006	Saddle frame	1
9	ZGR10015	Cylinder spacer	4
10	ZGR10142	Chassis cylinder	1
11	ZGR10189	Overflow screw M18x1.5	1
12	FW30	Plain washer M30 OC DIN 125	2
13	ZGR10095	Universal pin OC 8mm	2
14	ZGR10112	Wire clamp 15mm	2
15	ZGR10161	Pressure screw M10 DIN 913	2
16	BM162080	Screw M16x80 OC 8.8 DIN 931	1
17	FW16	Plain washer M16 OC DIN 125	2
18	LN1620	Self-locking nut M16 OC DIN 985	1
19	ZGR10018	Height adjustment profile	1
20	ZGR10014	Bumper spacers	2
21	ZGR10114	Rubber bumper	1
22	ZGR10170	Universal pin OC 6mm	1
23	FW25	Plain washer M25 OC DIN 125	1
24	ZGR10019	Bottom pin of the cylinder	1

Wheels

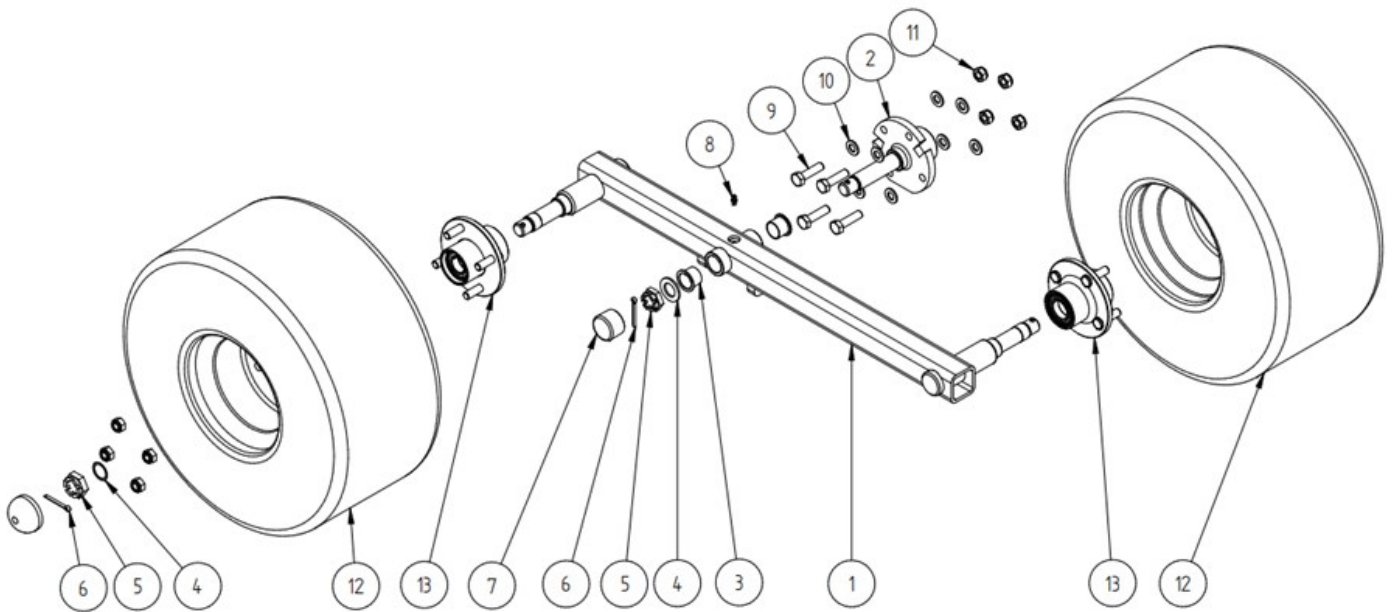

Wheels

Item	Part #	Description	Qty.
1	ZGR10010	Right tandem	1
1a	ZGR10011	Left tandem	1
2	ZGR10008	Right interchangeable pivot	2
2a	ZGR10009	Left interchangeable pivot	1
3	ZGR10181	Sliding bushing PAF 25215	4
4	FW22	Plain washer M22 OC DIN 125	3
5	CNM2215	Nut M22x1.5 OC crown low DIN 937	3
6	CP5X40	Pin 5x40 OC DIN 94	3
7	ZGR10111	Flexible cap 34.9x38	4
8	GN081S	Grease nipple M8x1 DIN 71412-A	1
9	BM1217545	Screw M12x45 OC 8.8 DIN 933	4
10	FW12	Plain washer M12 OC DIN 125	8
11	LN12175	Self-locking nut M12 OC 8 DIN 985	4
12	ZGR10179	Wheel AB 18x8.5-8 81B STARCO HIT TR13	2
13	ZGR10180	Wheel hub	2

Swath Scraper

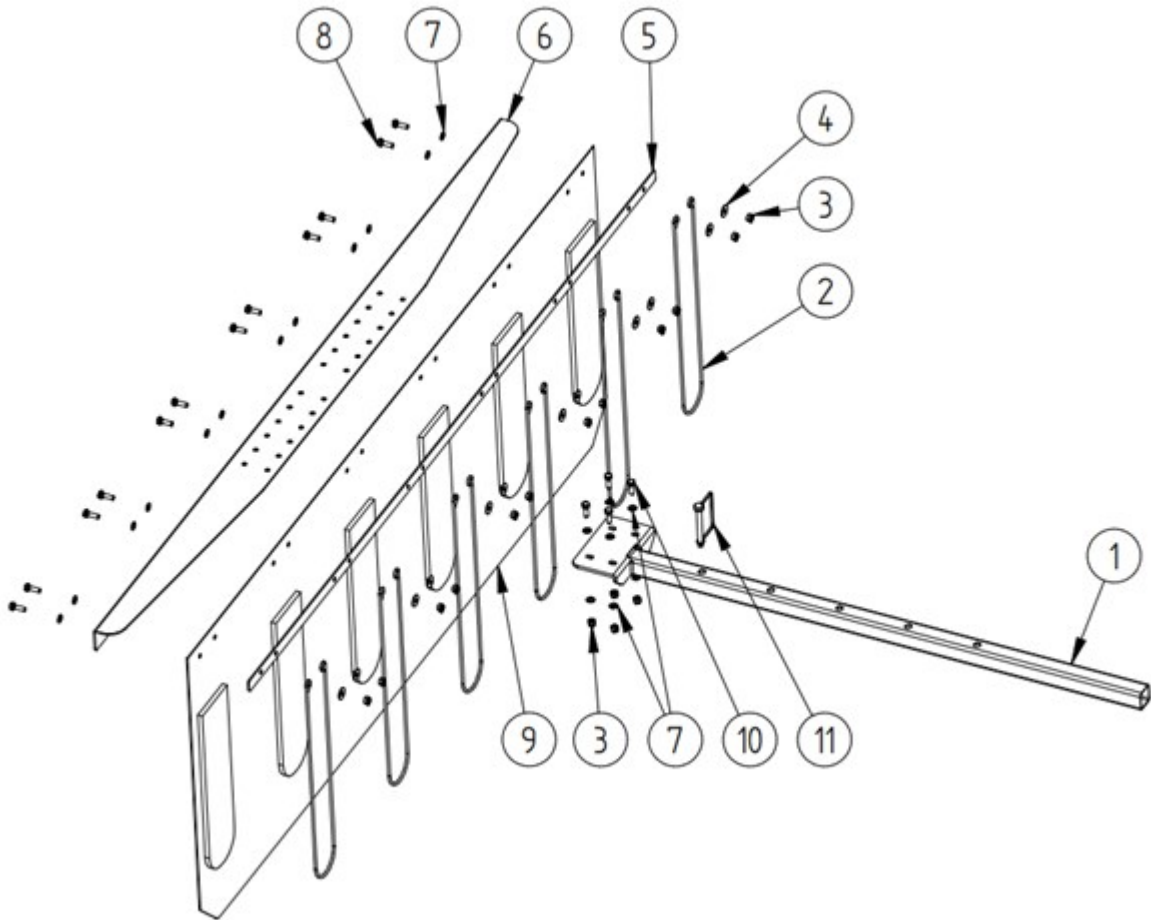

Swath Scraper

Item	Part #	Description	Qty.
1	ZGR10066	Swath arm	1
2	ZGR10087	Stiffening element 500x84x5	2
3	LNLM08125	Self-locking nut M8 oc	16
4	LFW08	M8 pad enlarged oc	12
5	ZGR10067	Mounting strip	1
6	ZGR10068	Fixing for the tarpaulin	1
7	FW08	M8 flat washer oc	20
8	BM0812525	M8 Bolt x25-8.8 oc	4
9	ZGR10088	Apron for rake 5272/512-05-202	1
10	ZGR10160	M8 Bolt x30-8.8 oc	12
11	ZGR10172	Folding pin 12x67	3

Warranty

LIMITED WARRANTY

Belco Resources Equipment warrants to the original purchaser of any new piece of machinery from Belco Resources Equipment, purchased from an authorized Belco Resources Equipment dealer, that the equipment be free from defects in material and workmanship for a period of one (1) year for non-commercial, state, and municipalities' use, ninety (90) days for commercial use from date of retail sale. Warranty for rental purposes is thirty (30) days. The obligation of Belco Resources Equipment to the purchaser under this warranty is limited to the repair or replacement of defective parts.

Replacement or repair parts installed in the equipment covered by this limited warranty are warranted for ninety (90) days from the date of purchase of such part or to the expiration of the applicable new equipment warranty period, whichever occurs later. Warranted parts shall be provided at no cost to the user at an authorized Belco Resources Equipment dealer during regular working hours. Belco Resources Equipment reserves the right to inspect any equipment or parts, which are claimed to have been defective in material or workmanship.

This limited warranty does not apply to and excludes wear items such as shear pins, tires, tubes knives, blades or other wear items. Oil or grease is not covered by this warranty.

All obligations of Belco Resources Equipment under this limited warranty shall be terminated if:

- Proper service is not performed on the machine.

- The machine is modified or altered in any way.

- The machine is being used or has been used for purposes other than those for which the machine was intended.

DISCLAIMER OF IMPLIED WARRANTIES & CONSEQUENTIAL DAMAGES

Belco Resources Equipment obligation under this limited warranty, to the extent allowed by law, is in lieu of all warranties, implied or expressed, including implied warranties of merchantability and fitness for a particular purpose and any liability for incidental and consequential damages with respect to the sale or use of the items warranted. Such incidental and consequential damages shall include but not be limited to: transportation charges other than normal freight charges; cost of installation other than cost approved by Belco Resources Equipment; duty; taxes; charges for normal service or adjustment; loss of crops or any other loss of income; rental of substitute equipment, expenses due to loss, damage, detention or delay in the delivery.

REGISTRATION

The online Warranty Registration must be completed in order to qualify for coverage on this Limited Warranty. Visit br-equipment.com, click on "Warranty Registration" and completely fill out the form to register the new piece of equipment.

Page left blank intentionally



401 Jeffreys Road
Rocky Mount, NC 27804
www.tarrivermfg.com

Tel: 252-822-7140
Fax: 252-787-5855
Sales@tarrivermfg.com