

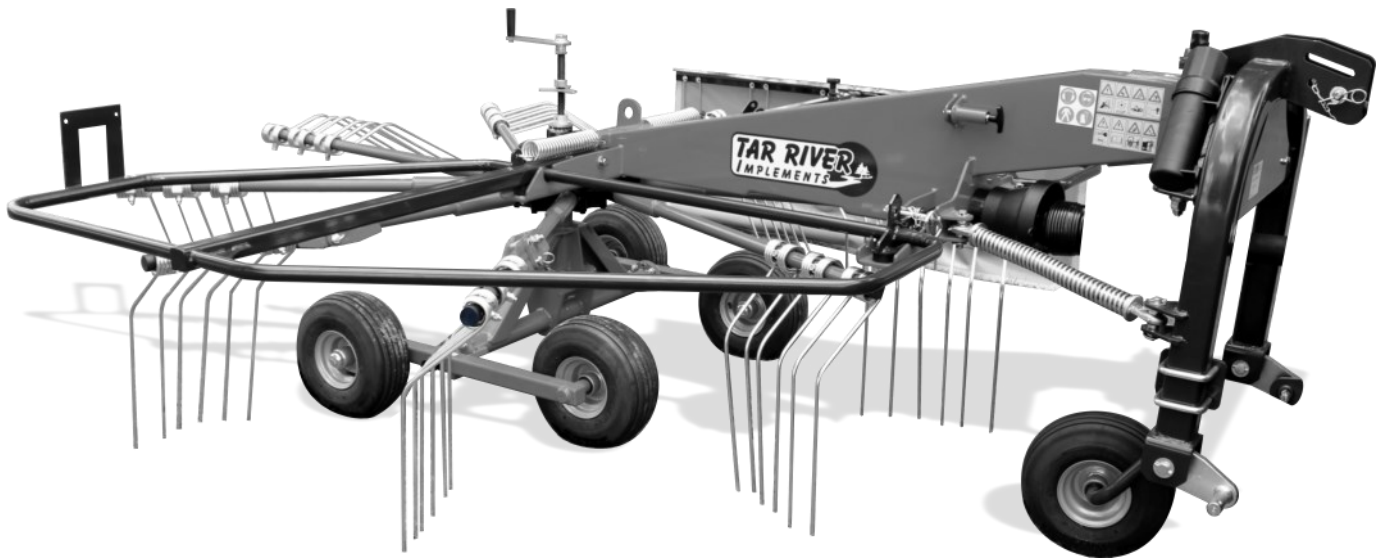

Rotary Rake

ZGR-360



Operator's Manual

Rel. 09/24

Page left blank intentionally

Table of Contents

1. Introduction	4
2. Machine identification.....	5
3. Guidelines for safe operation	6
3.1 User safety.....	6-9
3.2 Residual risk assessment.....	9-10
3.3 Warning decals on the machine	11-12
4. Intended use of the machine	13
5. Description of the machine.....	14
5.1 Technical characteristics - technical details.....	14
5.2 Technical characteristics – major components	14-15
6. Operating principals	16
6.1 Attaching to tractor	17-19
6.2 Preparing the machine for operation.....	19-20
6.3 Preparing the machine for transport.....	20-23
6.4 Raking and forming of windrows	24
6.5 Tine arms operation.....	24-26
6.6 Folding and unfolding of safety barriers	27
6.7 Swath width adjustment	28
6.8 Working height adjustment.....	29
6.9 Ground contour tracking	30-31
6.10 Additional equipment – support wheel	32
7. Lubrication and maintenance	33
7.1 Inspection and maintenance of raking tines	34
7.2 Post–operation maintenance	35
7.3 Lubricating machine.....	35-38
7.4 Post–season maintenance	39
8. Disassembly, disposal and environmental protection	40
9. PTO Driveline Instructions	41-44
10. Torque Specifications.....	45
10. Parts Breakdown.....	47-65
11. Warranty.....	66

Introduction

1. Introduction

This document covers the most recent data available at the date of its publication. Due to the development of the product some of the drawings and parameters described may not fully represent your machine. The manufacturer reserves the right to introduce changes in construction and design of the machine in order to improve its safety and functionality without making any amendments to the operating manual if the modifications can be considered as minor and not affecting operator's safety and working principals of the machine stay as before.

A full and thorough reading and understanding of all sections of this manual should be completed prior to trying of the machine for the first time. The rules and recommendations contained in this document must be adhered to at all times.



CAUTION

Familiarize yourself with the operating manual prior to operating this machine.

This operating manual contains the description of all risks, which may occur in case of not observing the safety rules when operating and maintenance of this rotary rake. The safety precautions are listed in this document and should be adhered to in order to minimize or avoid the risks.

This manual explains working principals of the machine and contains instructions on how to carry out all operations with this machine safely.

In case of any doubt arising or if the information in the manual is insufficient, please ask the manufacturer directly for detailed explanation of the issue.

CAUTION



This symbol represents danger or warning. This symbol highlights the place in the manual where there is important information about the need for special care and attention. Reading of this section and adherence to the recommended safe operation is compulsory.

Identification of the Machine

2. Identification of the machine

The ZGR Rotary Hay Rake can be identified by the serial plate. The plate is located on the main headstock of the machine, in a prominent location and easy to access. Under no circumstances should the identification plate be removed from this machine or used for another machine.



Note: If replacement parts are needed, warranty or service issues arise, it is imperative to give the Model Number and Serial Number of the machine to accurately identify the machine.

Guidelines for Safe Operation

3. Guidelines for Safe Operation

3.1 User safety

This hay rake can be operated only by a qualified adult person, familiarized with its operating principals and the content of the operating manual. The machine should be always handled with utmost care.

- The Basic Health and Safety rules should be used in addition to the recommendations included in this operating manual. Always comply with warning symbols on the machine.
- The operator must have the sufficient qualifications to drive a vehicle to which the hay rake is attached, in compliance with the manufacturer recommendations or current legislation.
- Be vigilant for places on the machine posing injury risk (sharp or pointed edges of the machine, etc.). Exercise due caution near critical places, especially whilst performing any kind of task requiring being close to the machine e.g. service, maintenance, making manual adjustments etc. Protective outfit should always be worn including protective clothing, gloves, safety boots and protective goggles.
- Read operator's manual prior to use of this implement in order to familiarize yourself with its working principals, risk management and recommendations regards operation and adjustment.
- Do not use the rotary rake with any missing factory-provided guard or cover limiting access to hazard zones. Keep all safety guards and covers in working condition and check regularly for their completeness.
- Due to the residual risk involved, it is imperative that all the rules and recommendations featured in this operating manual as well as common sense are followed at all times. Reasonable conduct is advised.
- Under no circumstances the machine should be operated by persons being under the influence of alcohol or of any other intoxicating agent.
- This machine should be only operated by the driver of the tractor (no passengers allowed). No one should remain in the vicinity of this machine while working.
- Do not use this implement against its intended purpose. Other than intended by the manufacturer use will be considered as misuse and will void the warranty as well as will exempt the manufacturer from liability for damage caused as result of such conduct.
- In case of any doubt arising regards this machine or any piece of information included in this document, please ask the manufacturer or your dealer for detailed explanation of the issue.
- Misuse, reckless behaviour around the machine and ignoring of the warnings included in this operating manual can pose unnecessary threat to life, health.
- It is recommended to check the technical condition of the machine every time before work commencement. Pay special attention to the condition of headstock, linkage pins, safety pins, chassis, PTO shaft safety covers, safety guards, crop tines etc. It is forbidden to operate the machine out of order.

Guidelines for Safe Operation

3. Occupational safety regulations

- Do not carry persons or things on the machine.
- Before linking to the tractor, place the machine on a hard, flat surface, lower down the support stands and lock the chassis in place by means of wheel blocks. Beware of potential stabbing hazard whilst moving near the arms which are folded in the transport position. To reduce injury risk always cover upwards facing tines with the provided protective yellow sleeves at all times..
- **Do not power up the machine with the rotor arms in the transport position. Powering up the rotor when locked in place can cause permanent damage to the rotor gearbox and the power take off drive line.**
- No one is allowed to stand in-between the implement and the tractor whilst connecting the tractor three point linkage. This area is considered a crush zone.
- Extra care must be exercised when linking the implement to the tractor.
- The headstock of the machine is designed for use with rear tractor three point linkage of category I/II and it should not be used with any different category.
- To secure three point linkage pins from falling out use only typical cotter/ linch pins supplied by the manufacturer. Work with non-standard safety pins or without any safety pin is forbidden.
- Make sure the correct type of PTO shaft is used and it has suitable movement within the operation zones, if in doubt, consult operator's manual for PTO shaft.
- Do not use PTO shaft with no safety covers on or when the safety covers or the PTO shaft itself are damaged. Remove the fault if possible or replace the item with new.
- To prevent the PTO shaft safety cover from spinning, connect the safety chain to a rigid, not moving element of the machine.
- Always have the PTO shaft connected to the tractor and to the machine to prevent damage in transit. Do not use safety chains of the PTO shaft to support it whilst in transport.
- After connecting the PTO shaft check the correctness of the connection at both ends. Make sure that safety covers and chains are in place.
- Before you power the implement up:
 - Make sure that the direction of rotations of the PTO shaft is correct.
 - Check if the tine arms are set in correct position and are appropriately secured.
- Make sure no one stays in the hazard zones. Be especially vigilant for children and animals. The Operator is responsible for keeping sufficient visibility of the machine and work area.
- The rotary rake should not be used or transported at night or when the visibility is poor as it creates unnecessary risk of an accident involving other road user.
- Do not exceed the PTO operating speed at 540 rpm.
- Avoid placing of the drive assembly under sudden load whilst starting work. Always increase the rotations gradually.
- **It is imperative to cut off the power supply from the tractor before reversing the tractor with the mounted machine or before making U-turns. Manoeuvring with the powered machine can cause damage to the drive assembly.**

Guidelines for Safe Operation

- Do not leave the driver seat when the machine is powered.
- It is the Operator's responsibility to make sure that no one comes within 50 m distance of the rotary rake whilst working due to the risk of ejecting object or coming into contact with hazard zones e.g. rotating parts.
- Make sure that the raking tines are set in correct position before starting work with the implement.
- Do not place your fingers or limbs in positions where they could be cut, crashed or trapped.
- Under no circumstances are you allowed to come in vicinity of the rotor or PTO shaft whilst in move.
- Before disconnecting the PTO shaft switch of the engine of the tractor, remove the ignition key and engage the hand brake.
- All operations should be done observing the Basic Health and Safety rules. In case of injury the wound should be immediately rinsed and disinfected.
- Any maintenance or repair works can be done only after the engine of the tractor was switched of and the ignition key was removed.
- Use protective gloves and appropriate tools whilst performing any work by the machine.
- Stop all operations immediately if any malfunctions or damages were revealed.

NEVER OPERATE A MACHINE THAT IS IN NEED OF REPAIR OR IS DAMAGED.

- To keep your machine safe and operable check its technical condition regularly. Pay special attention to all separable connections. Lubricate the greasing points following the manufacturer's recommendations. Inspect the condition, completeness and operability of all assemblies of the machine. Keep the correct tire pressure. Replace the damaged or worn part with new.
- Do not work under raised, unsecured machine. Use only attested, fully operable hoisting equipment of sufficient lifting capability. It is imperative to use additional solid supports to ensure safety in case of hoisting equipment failure. Never block the tires of the machine with fragile objects such as bricks or concrete blocks.
- Do not wear loose fitting clothes such as coats, unzipped or unbuttoned jackets or fleeces, scarfs or loose straps near the machine and tie the long hair up in a bun to minimize the risk of being caught by the rotating elements of the machine such as PTO shaft or the rotor. Under no circumstances come near the machine when it is powered or still in motion. Exercise special care whilst performing any service or maintenance task near hazard zones.
- When carrying post warranty service involving any welding works it is imperative to follow the rules listed below:
 - The welding works should be done by a qualified person.
 - Ensure there is sufficient lighting and ventilation in the work area.
 - Do not weld a tractor mounted machine due to the risk of fire or electrical short.
 - After removing the layer of paint and primer, clean and degrease the surface intended to weld. Remove excess of lubricant from the nearby grease points.
 - To minimize the risk of causing fire remove all inflammable elements of the machine if possible or use sufficient heat protection. Do not touch freshly welded surfaces to avoid the risk of burns.

Residual Risk Assessment

3.2 Residual risk assessment

Tar River Implements has made every effort to eliminate the risk of an accident. However, there is some residual risk, which can lead to an accident, and is primarily associated with the actions described below:

Residual risk

<i>NO</i>	<i>Risk</i>	<i>Risk source (cause)</i>	<i>Precautions and prevention</i>
1	Overload of the muscular and skeletal system (physical stress)	Working in standing, stooped or forced position, walking, moving heavy objects around	Familiarizing with the operating manual, operator's basic health and safety regarding manual lifting. Assess whether you need assistance to lift an object or use correct tools to assist you e.g. back belts, trolleys or mechanical aids to achieve movement.
2	Trip hazard and slippery surfaces	Uneven ground, obstacles, poor visibility, slippery or wet surfaces, untidy operating areas and walkways e.g. electric leads on the ground	Always be precautious, use footwear with a good grip and work with adequate light. Never obstruct walkways and take great care when walking on uneven or wet surfaces. Do not run in restricted areas. Keep your work area tidy.
3	Risk of walking into fixed, protruding parts of the machine	The machine and its surrounding	Beware of protruding parts whilst servicing the machine. Keep the walkways clear. Take special care whilst near the machine. Always wear protective clothing. Secure the raking tines which are pointing upwards in transport position by means of protective tarpaulin sleeves.
4	Risk of being hit by moving objects or parts	Material discharge, stones	Observe ground conditions, make sure all bystanders are at least 50 meters away whilst working with the machine. Always wear protective clothing, hard hat and goggles. Do not come in vicinity of the machine whilst powered or still in motion. Take special care whilst servicing rotating or moving parts of the rotary rake.
5	Sharp edges	Exposed sharp edges, hand tools	Wear personal protection clothes and gloves at all times. No flappy clothing allowed. Take spe-
6	The weight of suspended machine	Wrong assembly, badly made connection to the tractor or adjustment of the machine. Not complying with Health and Safety rules, leaving the mounted machine lifted up on the tractor linkage.	Take special care whilst near the suspended machine. Use protective outfit at all times- safety boots, safety gloves. Whilst performing inspection or service works use correct tools to lift up and secure the rotary rake in place to avoid risk of being crushed under the machine. Use assistance of the other trained person. Read operators manual carefully.

Residual Risk Assessment

7	Microclimate – changing weather conditions	Work performed in unsettled weather conditions	Proper protective outfit, beverages, protective cream with filter, rest
8	Noise	excessive rotations of the machine; damaged, loose or vibrating parts	Work only with fully operable machine. Control regularly condition of all assemblies of the machine. Follow the recommendation regards ap-
9	Head injury	Standing in crash zone when unfolding the safety barriers	Take special care when unfolding the safety barriers. Keep out of the crashing zones. Do not remove safety springs protecting against free falling of the barriers. Read the operators manual carefully.
10	Crushing injuries of the body	Sudden release of energy accumulated in the springs e.g. during service works	Exercise extra caution with spring loaded elements of the machine. Provide service works only when the machine and its elements are positioned in a safe way. Wear personal protection clothes, boots and gloves at all times. Use help of other qualified person when needed. Use correct tools. Do not work in hurry. Reasonable conduct advised.
11	Crushing injuries of the legs and cutting injuries of hands,	The crop deflector is mounted on a telescopic bracket and it is possible that the inner box profile of that bracket may get stuck inside the outer box profile.	Exercise extra caution. Do not work in hurry. Wear personal protection clothes, boots and gloves at all times. To release the element that got stuck, first try to move it sideways a little.
12	Risk of being trapped or pulled in	Staying near the hay rake when it is altering position e.g. when at work; rotating or moving parts of the machine; PTO shaft; not using safety barriers.	Beware of danger and never come close to the machine or driveline when in motion Do not wear loose fitting clothes. Wear clothes that will not snag on the machinery instead- preferably overalls. Remove jewellery that may snag - e.g. watch, rings, necklace. Keep long hair tied up. Read the operating manual carefully. Respect safety pictograms placed on the machine.

Warning Decals on the Machine

3.3 Warning decals on the machine

Safety decals



1.0 – Caution. Prior to operating the machine, read the operating manual.

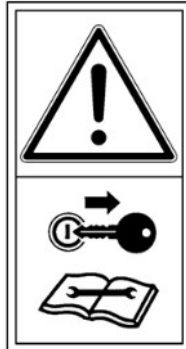

1.1 – Caution. Stop the engine and remove the ignition key before carrying out any repairs or maintenance.



1.2 – Thrown objects, pull-in accidents and other hazards. No persons allowed in distance less than 165 feet from the working machine.



1.3 – Caution. Wrap point - exposed, rotating driveline.



1.4 – Cutting hazard - Free moving parts. Do not touch rotating elements while in motion.



1.5 - Crush point. Keep away from linkage arms of the tractor hydraulic lift while in use.



1.6 – Caution. Entanglement, Exposed rotor assembly.











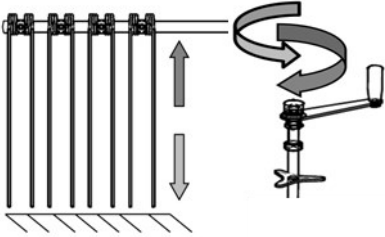

1.7 – High voltage - risk of electric shock. Keep sufficient clearance from power supply lines.



1.8 – Crush hazard. Keep away from the swing area around the safety barriers.

Warning Decals on the Machine

 <p>1.9 – Do not exceed the PTO operating speed at 540 rpm.</p>	 <p>1.10 – Correct position of the raking arms for chosen function: TRANSPORT- transport; PRACA- work.</p>	 <p>1.11 – Lift point</p>
 <p>1.12 – Raking height adjustment</p>	 <p>1.13 – Transport lock – It is imperative to lock the tine arms in transport position before transport on a public road</p>	 <p>1.14 – Lubrication point- use solid grease</p>
 <p>1.15 –Lubrication point- use oil to grease.</p>	 <p>1.16 – Do not exceed maximum tire pressure</p>	 <p>1.17 – Use ear protection</p>
 <p>1.18 – Use protective clothing</p>	 <p>1.19 – Use safety gloves</p>	 <p>1.20 – Use eye protection</p>

Intended Use of the Machine

4. Intended use of the machine

This rotary rake was designed for agricultural use in process of production of animal feed and bedding. It is intended for raking cut grass, hay or straw in uniform windrows or swaths. Machine should be use on stonless meadows or pastures where where stones were removed. Large stones can cause unnecessary machine damage.

Use of the machine in conditions other than above mentioned will be understood as its misuse. The manufacturer's recommendations and provisions mentioned in this operating manual should be strictly adhered to every time the machine is operated, maintained or serviced. Not applying to those rules will be considered as use of the machine against its intended purpose.

The machine can be operated, maintained and serviced only by trained personnel familiarized with its technical characteristics and Health and Safety rules.

The applicable provisions of Health and Safety as well as Highway Code should be adhered to at all times.

Unauthorized changes made without consent of the manufacturer will void the warranty and exempt the manufacturer from liability for damage caused as result of those changes.



All obscurities concerning intended use of the devices hall are explained by contacting with the machine manufacturer. Proper selection of a machine and the conscious of its intended use shall increase the operation safety.

Using the machine for purposes other than accepted shall be considered misuse.

Description of the Machine

5. Description of the machine

5.1 Technical characteristics - technical details

Lp.	Description	Unit	Value/Type	Unit	Value/Type
1	Overall length in transport position	[mm]	3550	[ft]	11'-7"
2	Overall length in working position	[mm]	3550	[ft]	11'-7"
3	Overall width in transport position	[mm]	2200	[ft]	7'
4	Overall width in working position (min.-max.)	[mm]	2800-3400	[ft]	9'-11'
5	Maximum height in transport position	[mm]	2300	[ft]	8'
6	Working width	[mm]	3600	[ft]	12'
7	Tractor horsepower requirement	[HP]	min.40	[HP]	min.40
8	Maximal PTO rotations	[RPM]	540	[RPM]	540
9	Recommended PTO rotations	[RPM]	300÷400	[RPM]	300÷400
10	Tare weight	[kg]	570	[lbs]	1257
11	Number of rotors	[pcs.]	1	[pcs.]	1
12	Number of rotating arms	[pcs.]	9	[pcs.]	9
13	Working capacity	[ha/hr]	3,4-3,9	[acres/hr]	8-10
14	Working speed	[km/h]	10	[miles/h]	6
15	Noise level	[dB]	<75	[dB]	<75
16	Number of wheels	[pcs.]	4	[pcs.]	4
17	Tire size	-	15x6.00-6	-	15x6.00-6
18	Tire pressure	[bar]	2,2-3,0max	[psi]	32-44max

5.2 Technical characteristics – major components

The construction of the machine is shown in Fig. 2. The headstock of the machine (1) is connected to the main frame (2) via the main pivot pin and additionally via a pair of steering rods with spring compression (4). The rods are mounted one at each side and are responsible for centralizing of the machine behind the tractor. The machine is fitted with 11-arm rotor (9).

Inside the rotor solid cast housing there is an oil-immersed cam track on which run cam rollers connected to the individual tine arm housings. This allows for smooth, low-friction transmission. The tubular tine arms are fitted into the arm housings. The movement of cam rollers provides simultaneously the pivoting and rotary movement of the tine arms. In standard option, there are six folding arms (10) and five fixed ones (12), each fitted with a set of four, angled, double raking tines. The rotor is mounted directly on top of the undercarriage which is fitted with twin wheeled rocking beam system allowing for efficient contour following. Additionally, the machine has got a manual winding mechanism (8) to adjust tine height against the crop. After setting of the desired raking height, the threaded rod should be locked in place by means of a three-armed counter nut. The hay rake is equipped with a swath-forming screen (7) which is responsible with forming one windrow of raked mass. The width of the formed windrow is adjustable by means of extracting or retracting the profile which is mounted inside the profile of the left protective barrier, which is additionally secured with a pin and a lock to prevent from falling out. To limit the access to the working area of the machine, the rake has been equipped with right (5) and left (6) protective barriers.

Rotary Rake Major Components

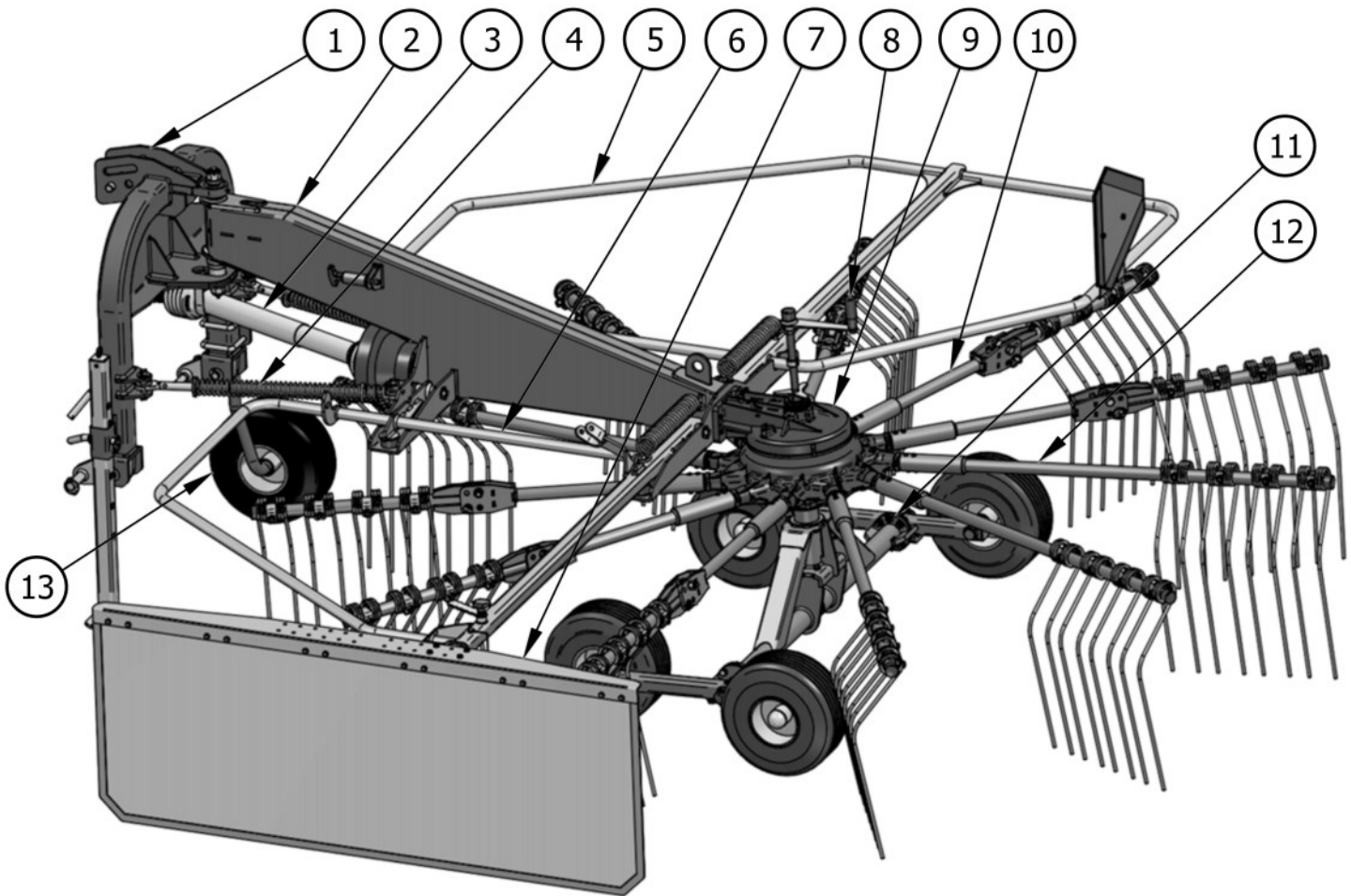

Figure 2. Single-rotor hay rake – main components

Legend:

1. Main hitch
2. Main frame
3. Drive transmission
4. Control link
5. Right barrier
6. Left barrier
7. Swath screen
8. Raking height adjustment mechanism
9. Main gearbox
10. Foldable raking arm
11. Chassis
12. Stiff raking arm
13. Support wheel

Operating Instructions

6. Operating instructions

The manufacturer ensures that the machine is fully operational and has been checked according to the quality control procedures and approved for use. However, this does not relieve the user from the obligation to check the machine after delivery, prior to starting it for the first time. Before performing any task concerning attaching of the hay rake to the tractor inspect its technical condition and prepare it for the trial start up. Follow the steps listed below:

- a) Familiarize yourself thoroughly with all pieces of information described in this operating manual, especially concerning the User's Safety, built of the hay rake, its functioning and operating principals, transportation, service and maintenance recommendations etc.
- b) With help of this operating manual, familiarize yourself visually with the built of the hay rake and placement of the safety alert pictograms located on the machine near the specific hazards. Make sure that you recognize thoroughly the meaning of all safety labels and what kind of danger do they represent. Be cautious when near the machine.
- c) Check if the machine is complete, especially that all separable connections e.g. threaded bolts, nuts, linkage pins, safety cotter/linch pins etc. are not missing.
- d) Make sure that all threaded connectors are tight.
- e) Check the condition of the tires and tire pressure.
- f) Check if the wheels are attached properly to the undercarriage.
- g) Check the condition of paint coating.
- h) Visually inspect the machine for any signs of damage incurred before or during delivery especially when loading/ unloading or in haulage. Be vigilant in particular for fractures, dents, cracks, punctures etc.
- i) Check if all the greasing points were primed with lubricant. Supplement the lubricant if needed. Follow the recommendations of the manufacturer as described in the chapter „Service and maintenance”.
- j) Inspect if the raking height adjustment mechanism work correctly.
- k) Make sure that the raking arms are attached properly to the rotor.
- l) Check the condition of the raking tines and if they are bolted up correctly to the raking arms.
- m) Make sure that the safety barriers were mounted in a correct way and are fully operable.
- n) Check the condition of the swat deflector, especially its tarpaulin shield.
- o) Inspect the condition and completeness of the headstock and linkage connectors. Make sure that nothing got damaged in transit and there are no missing elements e.g. linkage pins, linch pins, safety cotters etc.
- p) Check the gearbox against the leakages. Make sure that the level of oil in the oil compartment is sufficient.

Operating Instructions

6.1 Attaching to a tractor



WARNING

Do not work with broken down machine or tractor.

Use only typical cotter/ lynch pins supplied by the manufacturer.

Work with non-standard safety pins or without any safety pin is forbidden.

DO NOT WORK WITH THE TOP LINK PIN IN THE TRANSPORT POSITION AS IT WILL CAUSE DAMAGE TO THE HEADSTOCK AND LOSS OF THE

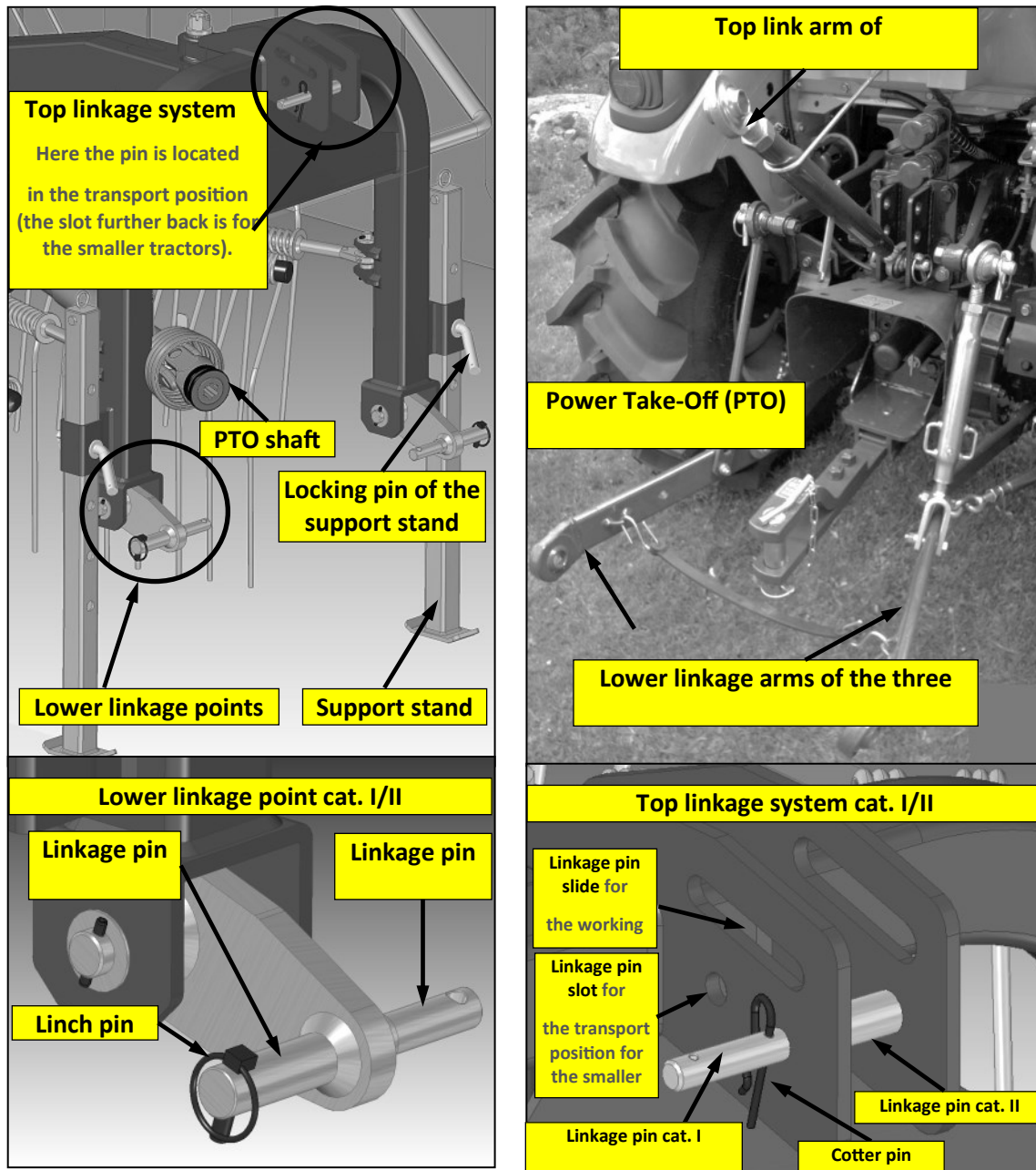

Figure 3. Linking of the hay rake to the tractor.

Operating Instructions

This rotary rake was designed to work with the tractors of more than 30 HP, fitted with the rear three point linkage of category I or II. Attaching of the machine to the tractor should take place on the hard and level surface.



Caution

Familiarize yourself with the operating manual before attaching the hay rake to the tractor. Extra care must be exercised when linking the implement to the tractor.

In order to link the hay rake to the tractor:

- Reverse the tractor to the machine,
- Cautiously realign the three point linkage of the tractor with the headstock of the machine. Bear in mind that no one is allowed to stay near the machine and the tractor during the tractor manoeuvres, especially to stand in between the tractor and the machine when the machine is hitched up.
- Put the tractor lower linkage arms as close as possible to the lower linkage points of the machine
- Stop the tractor, put all controls in neutral and engage the hand brake. For the safety reasons it is recommended to stop the engine and remove the ignition key whenever you leave the operator's seat in the tractor cab. **Make sure the handbrake is fully engaged.** You need to take extra precautions when safe stop is not possible, e.g. when operating external controls.
- Start connecting the implement with the left hand lower link arm, as you can adjust the right hand lower link arm stay rod easy. Always make sure after connecting the implement that the lower link arms are level. Use the linkage pin of category matching the category of the three point linkage on the tractor.
- Secure the lower linkage points from falling out using the lynch pins.
- Lift the implement slightly, retract the stand into its working position and lock it off with pin supplied.
- Then lower the machine down again.
- Release the top link arm from the transport lock and connect it to one of its fixed position holes on the headstock. Secure the top link using the linkage pin of category matching the category of the three point linkage on the tractor (see figure 11 above). Secure the linkage pin with a cotter pin. **Note that the slide is only to be used in work.** Use of the slide in transport can cause serious damage to the machine as a result of unnecessary stresses transferred to the main pivot pin. **Always use the correct slot for transport / work.**

Operating Instructions

Damage occurred in consequence of not adherence to that vital manufacturer's guideline will cause loss of warranty.

- **Prepare the PTO shaft.** Bear in mind that the tractor engine must be stopped first. Make sure that all

Caution



Use only the PTO shaft recommended by the manufacturer of the machine. Make sure the PTO shaft is of the correct length (look for further information of how to cut it in the operator's manual supplied with the PTO shaft).

guards and

safety chains are in place and not damaged. If so replace them before starting work. Check if the PTO shaft is of the correct length. It should have approximately 1/3 of the shaft overlapping as the minimum. But also check that the inner shaft has not bottom out on the outer shaft (i.e. it is pressed too far inside so that it touches the blind in the universal joints carrier). If the shaft length is found to be insufficient or not cut to the correct measurement serious damage can occur to both tractor and implement. Not following the manufacturers guidelines can result in unconditional void of warranty.

- Connect the PTO shaft fitting the side with the ratchet clutch to the drive shaft of the hay rake. Check the further manufacturer's recommendations in the
- Operator's manual of the PTO shaft.
- Take the driving seat in the tractor cab, start the engine again and lift the hay rake into the transport position.

Caution



Before using of this machine make sure that there is adequate clearance between the headstock and cab fixtures when lifting with the very short top link. Always check clearance margins before use.

6.2 Preparing the machine for operation

After transport of the rotary rake to its work place change its configuration for work. All activities regards preparation of the machine for work can be done only directly in its work place. Do not transport the machine on the public roads with the arms and barriers unfolded.

Follow the tips given below to prepare the hay rake for work after arrival in its work place:

Lower the machine down on a level surface so that it stands on its wheels.

Safe stop the tractor (fully engage the handbrake, put all the controls in neutral, stop the engine and remove the ignition key).

Get out of the tractor cab and approach the machine.

Put the top linkage pin in the slide for the work position (see figure 3 above). When the machine will be raised, e.g. on the headlands, the pin will slide in the slide to its maximum position and the steering rods will compress locking the machine from pivoting. Beware of clearance margins between the headstock and cab fixtures when lifting with the very short top link.

Operating Instructions

- Remove the protective sleeves from the raking tines.
- Free the first folding arm from the transport lock, unfold it and secure it in work position. Then unfold and secure the rest of the folding arms (see the subchapter No 6.5).
- Unlock and unfold the safety barriers (see the subchapter No 6.6).
- Pre-set the width of the windrows (see the subchapter No 6.7).
- Adjust the raking height (see the subchapter No 6.8).
- Make sure that the PTO shaft it is fully operable. Double check that it was adapted properly and safely connected to both the machine and the tractor.
- Check if all of the pins are secured from falling off with the safety cotter/linch pins.
- Without putting the machine under load carry out its trial start up with rotations at low speed to check if all the assemblies work correctly. The trial start-up should last several minutes. Be vigilant for untypical noises coming from the drive assembly e.g. crackling, grinding or knocking sounds. Ensure that the direction of the rotations of the rotor is correct and that the cam mechanism works properly and the arms are lifted and rotated in the correct moment. The work of the hay rake on the neutral gear should be flowless and without intensive vibrations. Ringing sounds or vibrations can be caused by the loose threaded connectors. After trial start-up inspect the drive assembly and the rotor for failures or leaks. In case that any failure was revealed, try to localize and remove its source by carrying out necessary repairs. Contact with the Seller of the machine if the problem is more serious and cannot be easily dealt with.

Caution



Make sure that the machine is in good technical condition before starting work with it. Check especially such elements as the raking assembly, undercarriage, safety guards and barriers are complete and operable. Remember to inspect the mounting of the raking tines.

6.3 Preparing the machine for transport

After finishing work, the machine must be folded to transport position and properly secured for transport. After finishing work, turn off the tractor engine and remove the key from the ignition switch. Then, immobilize the tractor by activating the parking brake and secure the driver's cab against intrusion by other people when preparing the rake for transport. It should be remembered that driving on public roads is forbidden after dark and in conditions of limited visibility.

The work should begin with the swath screen assembling. The steps are the same as for disassembly, except in the reverse order (see information in chapter 6.7). Then you need to assemble the protective barriers. The steps are the same as for unfolding except in the reverse order (see information in chapter 6.6). The next step is to fold the folding arms. Folding should be done in the same way as unfolding, but in the reverse order (see instructions in chapter 6.5).

Operating Instructions

Then, put on protective aprons on the protruding raking fingers and secure against slipping by tying the ropes. It is also recommended to remove the PTO shaft. However, should the shaft not be dismantled, please note on the categorical prohibition of engaging the roller drive during transport.

After the performed activities, go back to the operator's cabin, start the tractor and lift the machine up using the links. When lifting the machine, the main pin connecting the frame with the hitch moves in the slot until it stops, at the same time the control rods are shortened, permanently stiffening the machine during transport. When lifting the rake, the area between the tractor and the machine must be monitored all the time to prevent the upper hitch and barriers from colliding with the driver's cab.

When transporting the rake in a suspended and lifted form over long distances, the machine should be additionally secured against uncontrolled inertial tilt caused by hitting unevenness on the road. For this purpose, a blocking bolt is used, which limits the possibility of machine movement.

Procedure.

In order to protect the machine against uncontrolled inertial tilt during transport, it must be secured with a special transport lock. To secure the machine with a bolt, it is necessary to first set it in the raised position. The next step is to slide out the securing pin and pull the protection up. The previously removed protection should be placed in the suspension frame from below. Lock this protection with a cotter pin. Pay special attention when carrying out protective work.

Operating Instructions

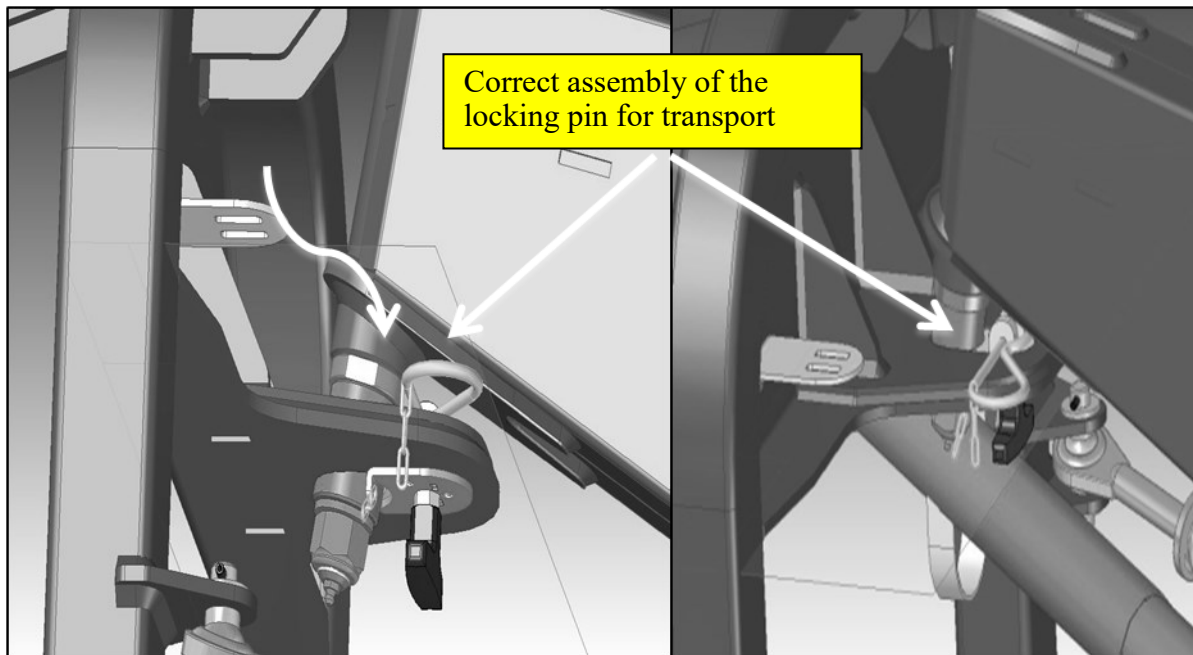
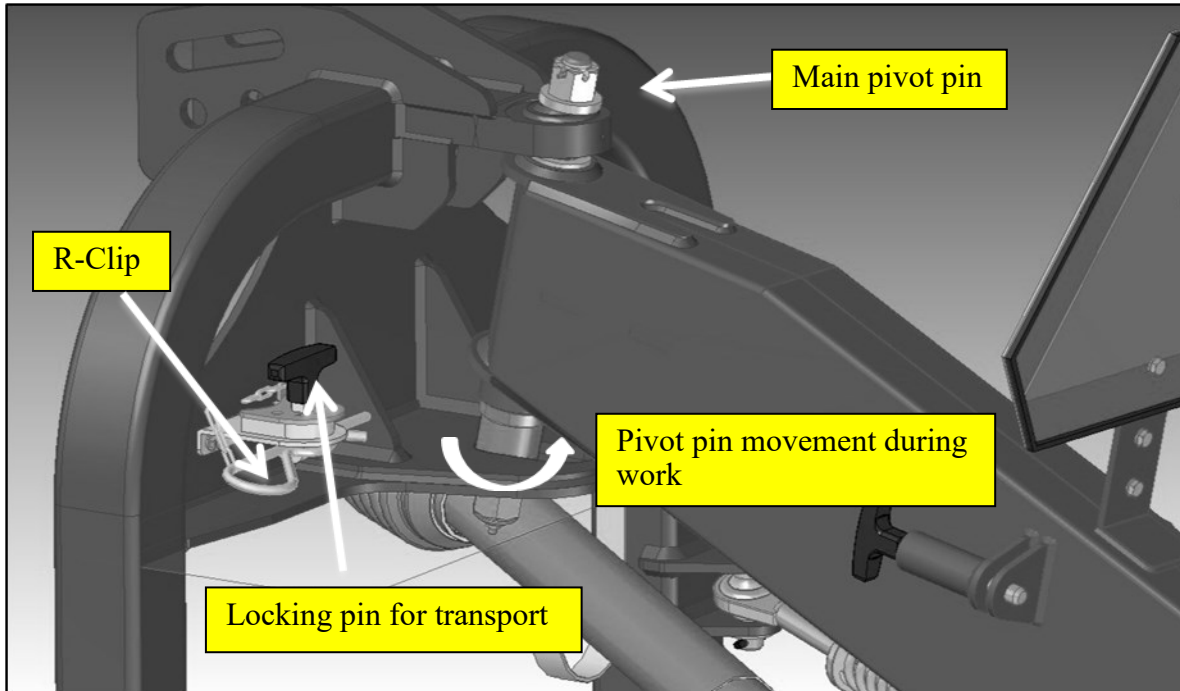

Figure 5. – Method of placing the transport locking pin

Operating Instructions

After correctly assembling the protection device and making sure that all movable elements of the machine have been secured against free movement, you can proceed to transport. Transport should be carried out in a safe manner and in accordance with the law.

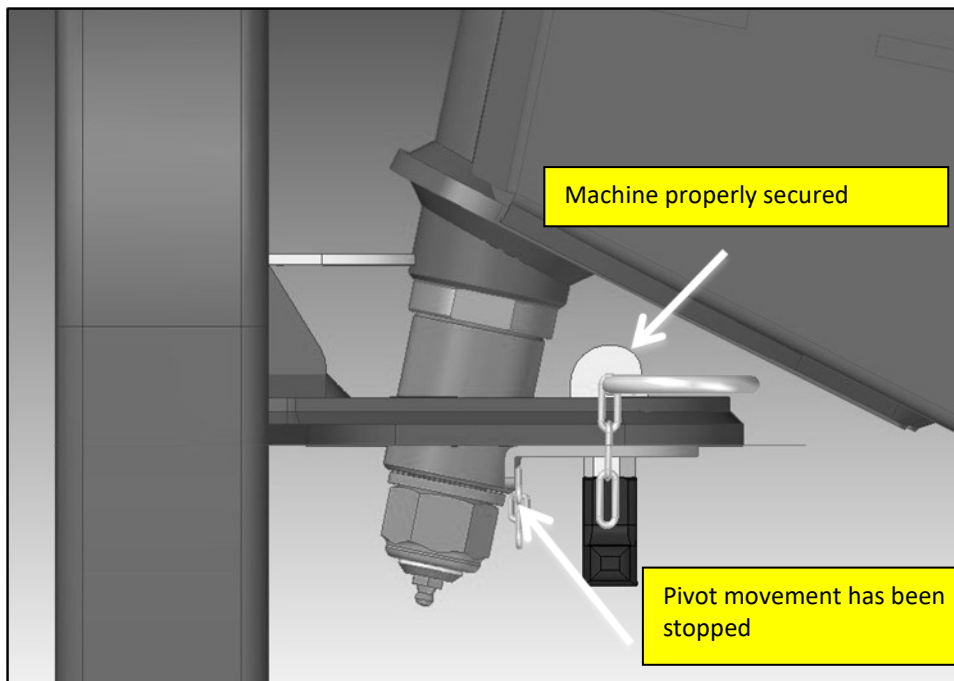

Figure 6. Machine properly secured for transport

Note that when the machine is being transported separate from the tractor e.g. on a trailer or a lorry the PTO shaft should be appropriately secured e.g. strapped to the machine. Do not use the PTO chains to support the weight of PTO shaft at any times as they are only to be used to prevent PTO guards from spinning when at work. **Never enable the Power Take Off when transporting the tractor mounted hay rake with the connected PTO shaft.** After carrying out all of the actions described above go back to the tractor cab, power the engine up and lift the mounted machine into the transport height. Beware of clearance margins between the headstock, barriers and cab fixtures when lifting with the very short top link.

Caution

Do not allow any person to stay near the machine when folding it up for the transport.



Before starting work, we act in the opposite way to securing for transport. The locking bolt must be removed to unlock the machine. To do this, remove the safety lock, place it in the gripper and secure it with a cotter pin (machine in raised position).

Operating Instructions

6.4 Raking and forming of windrows

The rotor constitutes the main working element of the hay rake and it consists of a reduction gearbox equipped with 11 arm housings to accommodate tine arms. Via PTO shaft the torque is transferred from the tractor to main drive shaft located inside the main frame and then to the rotor gearbox. Transmission of the torque to the gearbox causes swivel movements of the rotor. Inside the rotor housing there are cam rollers connected to the individual tine arm housings. During swivel motion of the rotor, the rollers run on the cam track of special construction forcing their movement up and down as well as their pivoting motion. This allows for the fluid alteration of the vertical and horizontal position of the raking tines. In the raking phase the raking arms are lowered and the vertically set tines come into contact with the crop dragging it sideways in a sweeping motion. The thrown outwards crop stops on the crop deflector forming a uniform windrow. In the next phase the arms are lifted, the tines pulled out of the crop and angled in which position they stay until they reach the raking area again. This motion creates sufficient clearance not to drag the crop back into the raking area. Combination of all these features makes the machine thorough and efficient but gentle to the crop.

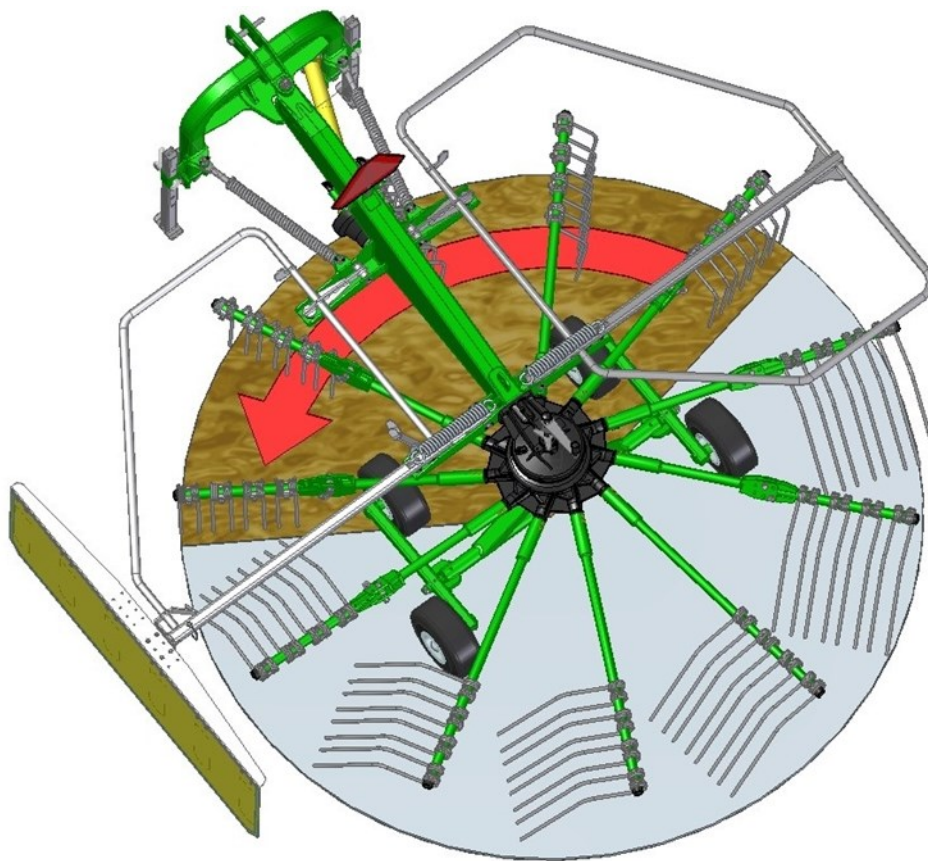

Figure 7. Working principals of the hay rake – The tinted field indicates raking area

6.5 Tine arms operation

Prior to work commencement the all six folding tine arms should be unfolded and locked in working position. As the first, free the arm inserted in a locking socket (transport lock) located on the frame near the rotor.

Operating Instructions

Caution



Do not power up the machine if any of the arms remains folded or if the safety barriers are not lowered into the working position. Serious damage will occur when not applying to this guideline. Carry out the safety check up to ensure that the machine can be started safely.

Follow the steps below to prepare the raking assembly to work:

- Remove the protective sleeves from the raking tines. The protective sleeves are made of bright warning yellow tarpaulin. Their function is to minimize stabbing risk by preventing direct contact of a person standing nearby with sharp tines of the raking arms. Take special care when folding and unfolding of the arms and stay clear of the movement zone of the arm. Be especially cautious when near the tines in the upper, transport position. Put the tarpaulin over the tines pointing upwards immediately after folding the arms into the transport position.
- Free the arm inserted in the transport lock to enable movement of the rotor. In order to do that, pull the safety lynch pin out and remove the pin from the socket of the transport lock. Then unfold that arm and reuse the same pin and the lynch pin to lock the folding part of the arm in the working position.

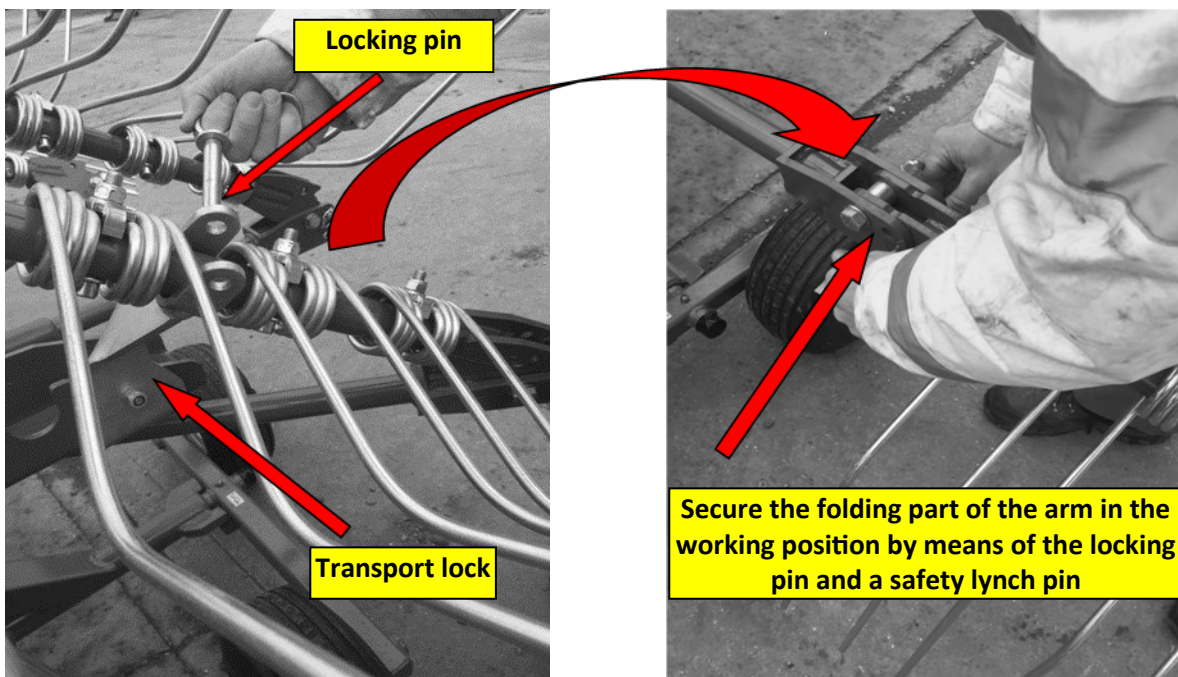

Figure 8. Freeing the first of the folding arms of the transport lock.

Caution



Do not power up the machine if any of the arms remains folded or if the safety barriers are not lowered into the working position. Serious damage will occur when not applying to this guideline. Carry out the safety check up to ensure that the machine can be started safely.

Operating Instructions

c) Repeat the following steps for the rest of the folding arms:

1. pull out the safety lynch pin,
2. unfold the arm into the working position,
3. insert the locking pin in the appropriate slot
4. to secure the arm in the working position,
5. secure the locking pin from falling out using a safety lynch pin.

1**2****3****4**

To prepare the tine arms for transport follow the steps from a) to c) in the reverse order.

Note that there should be two fixed arms at the front of the machine and three at rear to minimize transport width.

Operating Instructions

6.6 Folding and unfolding of safety barriers

For the security reasons the access of the user and the bystanders to the hazard zones on the machine should be appropriately restricted. The machine is equipped with the safety barriers to minimize the risk of accidental contact with the raking assembly whilst at work. The barriers should be lowered down after setting the arms for work and before powering the machine up. The barriers should stay in horizontal position at all times during work and after disengaging the power when the rotor is still in motion.

In order to lower down the safety barrier, grip the handle of the locking bolt firmly and pull it towards yourself to overcome the tension of the spring until you feel the resistance. Then grip the safety barrier with the other hand, pull it slightly outwards to free it from the locking socket and release the bolt. Grip the barrier with both hands and pull it down with force sufficient to overcome the tension of the safety spring, until it stops on the rubber buffers mounted on the frame. The right barrier should be additionally secured with a pin (marked with the letter "A" in the drawing below). Take special care while lowering down the barrier and do not stand in the movement zone of the barrier to avoid crushing risk.

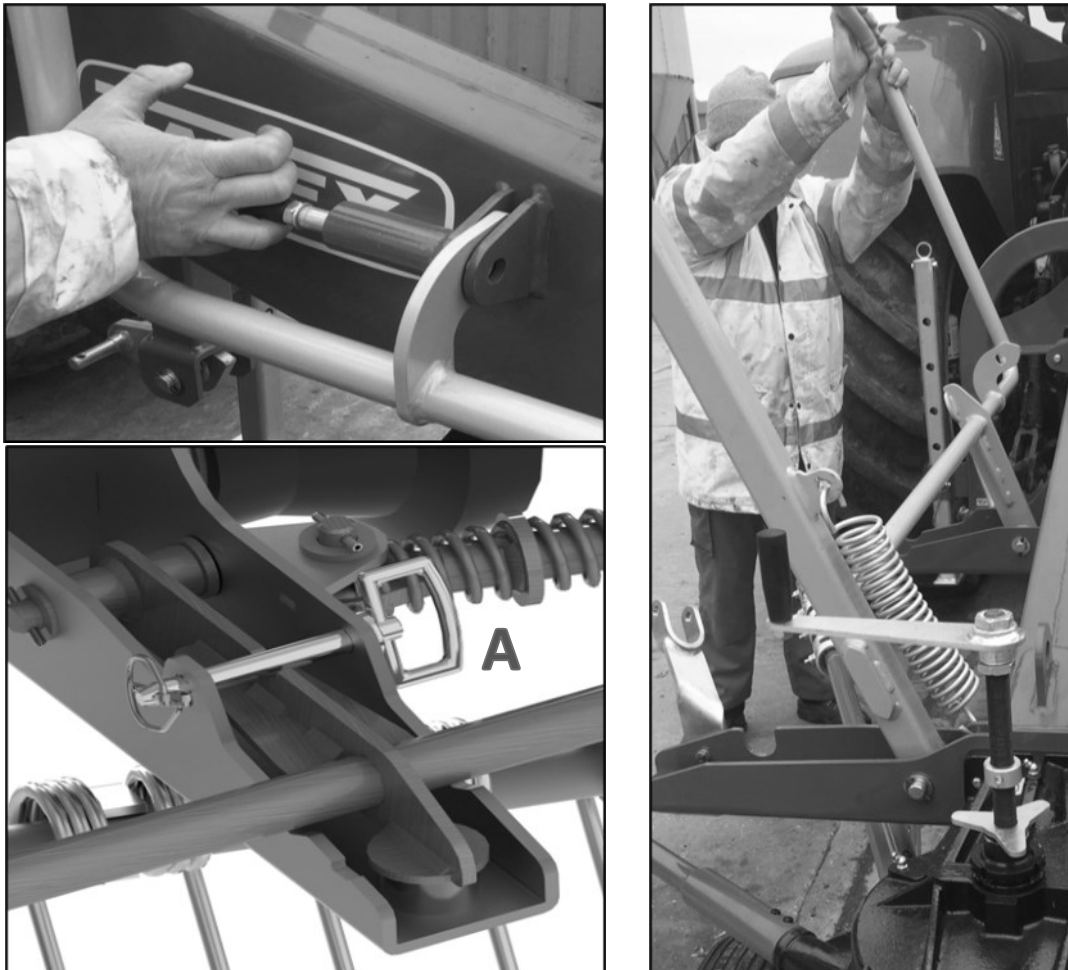

Figure 10. Unfolding of the safety barriers

Operating Instructions

6.7 Swath width adjustment

Depending on the needs, the width of the formed swath can be adjusted. To change the width, remove the fixing pin, loosen the tightening knob and the locking lever, and then extend the screen to the required width in the range from 0 - 620 [mm]. After adjusting, insert the cotter pin, tighten the knob clockwise and secure the knob with the locking lever. An additional possibility of adjusting the swath guide is changing the position of the screen in relation to the beam. There are 9 items available to the user. To change the position of the screen, unscrew the 4 mounting screws, then move the screen by the required value within the range from -250 to +250 [mm]. Fixing the mounting holes in relation to each other using the previously disassembled screws, screw again in order to clearly fix the screen to the beam.

When adjusting the cover extension, follow the rule that the larger the swath, the further the screen should be extended, and vice versa, with a smaller amount of swath, the distance of the screen should be smaller. Moreover, it should be remembered that when preparing the swath for a baler or other collecting device, the width of the formed shaft should be slightly smaller than the width of the pick-up.

Caution



Disengage the power and lower the machine down on the even ground before carrying out any adjustments.

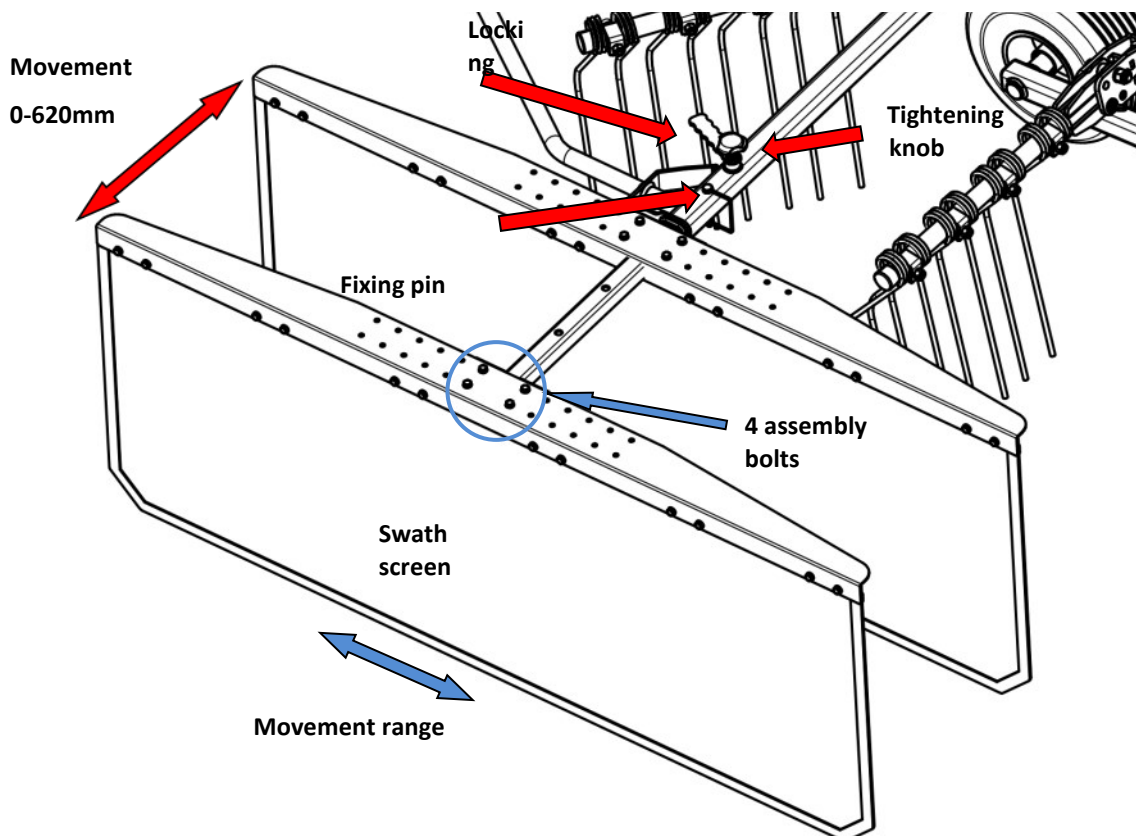

Figure 11. – Swath screen adjustment

Operating Instructions

6.8 Working height adjustment

Choice of the proper raking height is significant for the quality of work and material as well as the shape of the formed windrows. The lower arms of the tractor three point linkage should be adjusted as first. It is imperative that both of the lift arms are set at the same height. All necessary adjustment of the lower arms should be made before linking the machine to the tractor. The further adjustment should be made to the top link of the tractor's three point linkage in order to level the raking assembly regards the ground. The raking height should be set according to parameters such as volume and type of the swath, raking speed and the ground conditions.

The raking tines should be a little lower than the stubble with sufficient clearance of the ground so that that the crop is swept clearly but the turf is left undisturbed. Bear in mind that, when the tines are set too high, the rotary rake will not sweep the swath thoroughly. If, on the other hand, the tines are set too low, they will dig into the ground causing contamination of the crop with little stones, soil and fragments of turf. It will also put unnecessary stress on the drive and raking assembly of the machine. In this case the drive assembly and the raking tines can be damaged permanently from overload. The height adjustment mechanism allows for necessary corrections in the range of 80mm to match the given conditions. In order to change the raking height, loosen up the three-armed counter nut, grip the handle and rotate the threaded rod appropriately right or left till you achieve the demanded height. Then secure the threaded rod back in place by means of the counter nut. The adjustment range is 80mm.



Caution

Do not make any adjustments or corrections to the machine when it is powered. The machine should be lowered onto the firm and flat surface before making the adjustments.

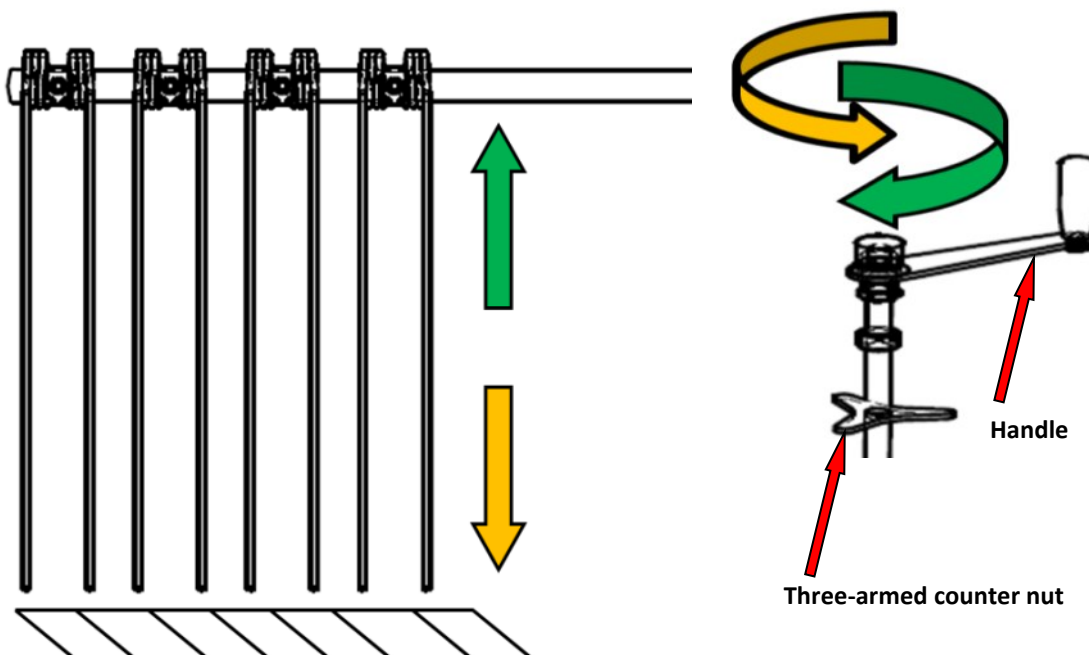

Figure 12. Raking height adjustment

Operating Instructions

6.9 Ground contour tracking

The design of the machine has been enhanced with several pivot points with sufficient range of movement to provide the maximum raking efficiency and smooth, undisturbed operation of the machine. The pivot points allows for contour following of uneven ground. Figure 13 (next page) shows the scope of movement of particular pivot points, such as:

- top linkage pin slide,
- oscillating lower linkage pins,
- the main pivot point with the floating pin
- spring loaded stirring rods
- twin-wheeled rocking beam.

The steering rods enhance the manoeuvrability of the hay rake. What is more, when the machine is lifted or transported, the rods make it more rigid restricting the movements of the main frame against the headstock. This in turn, reduces the risk of unexpected side movements compromising the stability of the machine during transport. The hay rake stays all the time behind the tractor and within its contour.

Operating Instructions

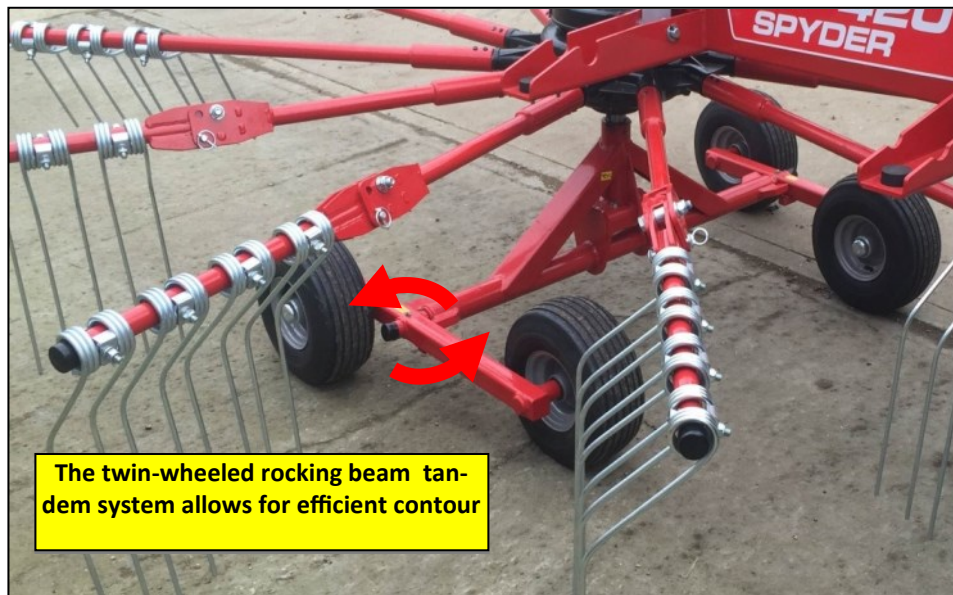
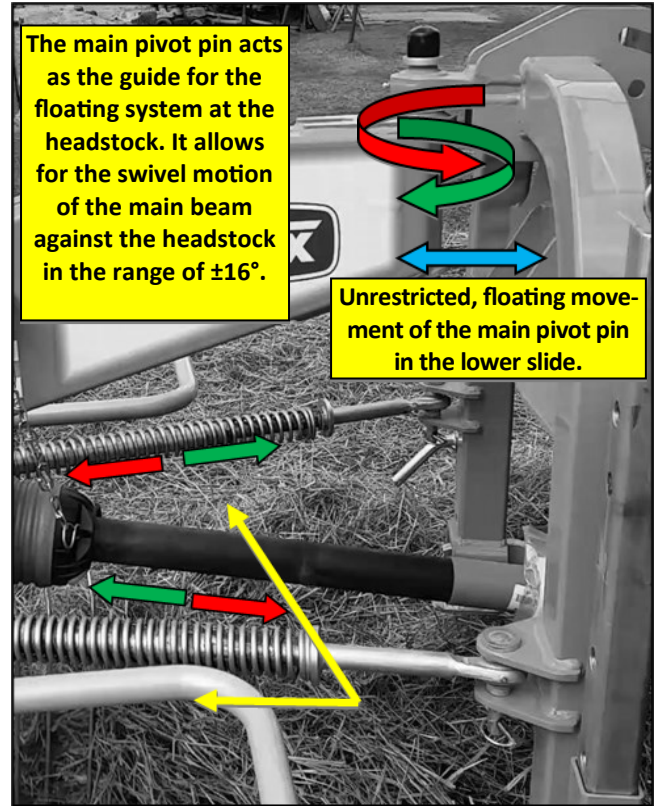
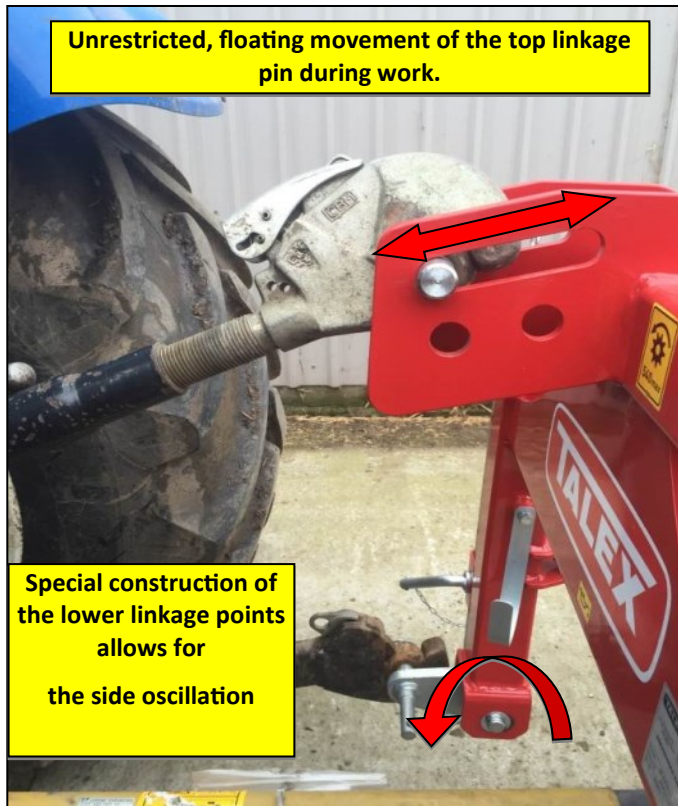

Figure 13. Range of motion of the particular components

Operating Instructions

6.10 Additional equipment – support wheel

In order to provide more stability during operation, Spyder 360 and 420 have been equipped with a front contour copying wheel.



ATTENTION!

Adjustment can be done only with machine turned off and on level ground!!!



ATTENTION!

There is a possibility of the machine tilting with support wheel not being mounted!

To adjust the wheel height, loosed the (4) Support wheel mounting hardware (as per picture below), then set the wheel to desired height. Secure the (4) Support wheel mounting hardware after adjustment.

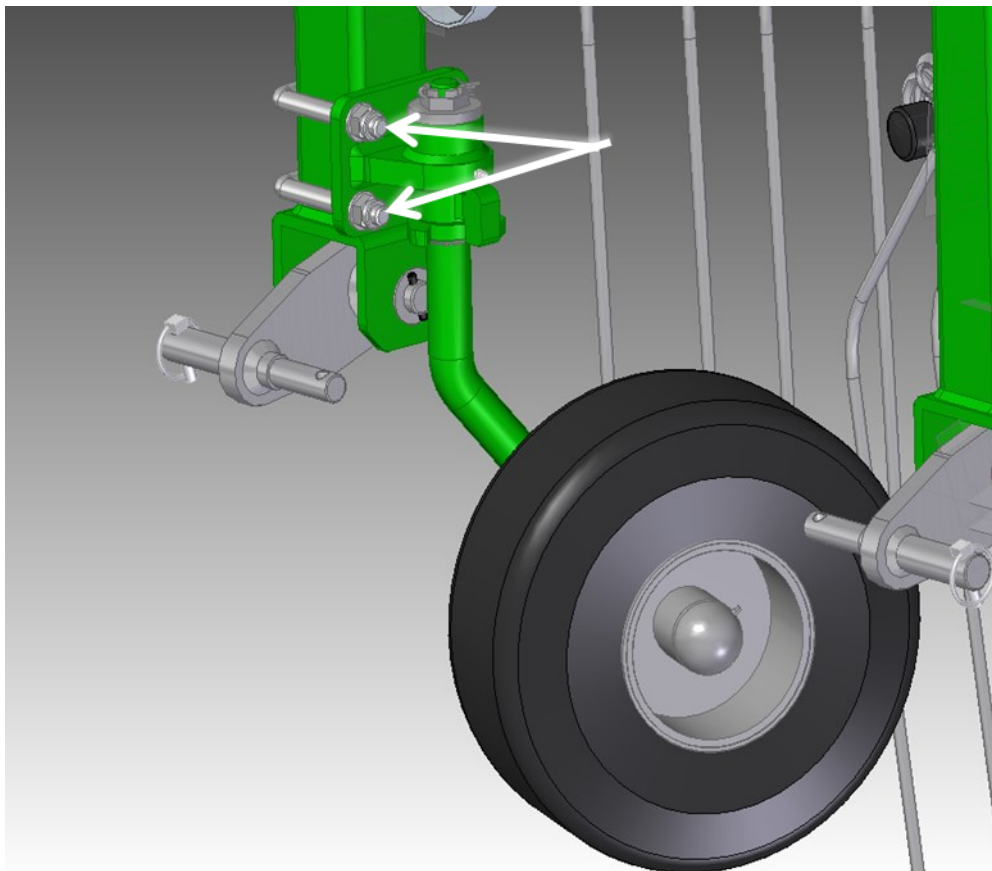

Figure 14. Support wheel

Lubrication and Maintenance

7. Lubrication and maintenance

All activities related to the maintenance of the machine may be performed by the user of the vehicle, to which it is connected, under the condition, that he is authorized to operate that vehicle.



ATTENTION!

After use machine should be stored under roof, on a flat, hardened surface with a support.

Prior to connecting the machine to the vehicle, the operator must inspect the technical condition of the machine each time and prepare it to the trial drive. For that purpose the operator must:

- Familiarize with this User Manual and follow the included suggestions
- Learn the design and understand the functioning of the machine
- Inspect all components of the machine for any possible mechanical defects
- Lubricate the machine in accordance with the suggestions
- Inspect the technical condition of the kingpins of the connecting system and the securing cotter pins
- Check the oil level in the gears
- Inspect the condition of the screw connectors
- Inspect the condition of the cutting blades; the worn should be replaced in pairs



ATTENTION!

Installing only the original manufacturer's parts may guarantee the safe and reliable operation of the device. Using generic parts or repairing damaged parts will cause loss of warranty.

If all mentioned above activities are performed and the technical condition of the machine does not raise any concerns, the machine may be then connected to the tractor.

Lubrication and Maintenance

7.1 Inspection and maintenance of raking tines

The raking tines were made of spring steel what allows them to bear dynamic loads easily. Nonetheless, despite of their strength and durability, the tines are subject to natural wear as a result of contact with the crop, stubble, obstacles etc. Additionally, constant vibration can cause the separable connections to go loose. For this reason, the threaded bolts and nuts securing the tines to the raking arms require regular tightening up. Before starting work, make sure that all of the raking tines are in good condition and each of the connectors is complete and not loose. The manufacturer recommends immediate replacement of damaged tine with a new one. Do not work with a damaged tine or missing connector and never attempt to repair the tine if it is faulty.

ATTENTION!



Do not make any adjustments or corrections to the machine when it is powered. The machine should be lowered onto the firm and flat surface before making the adjustments.

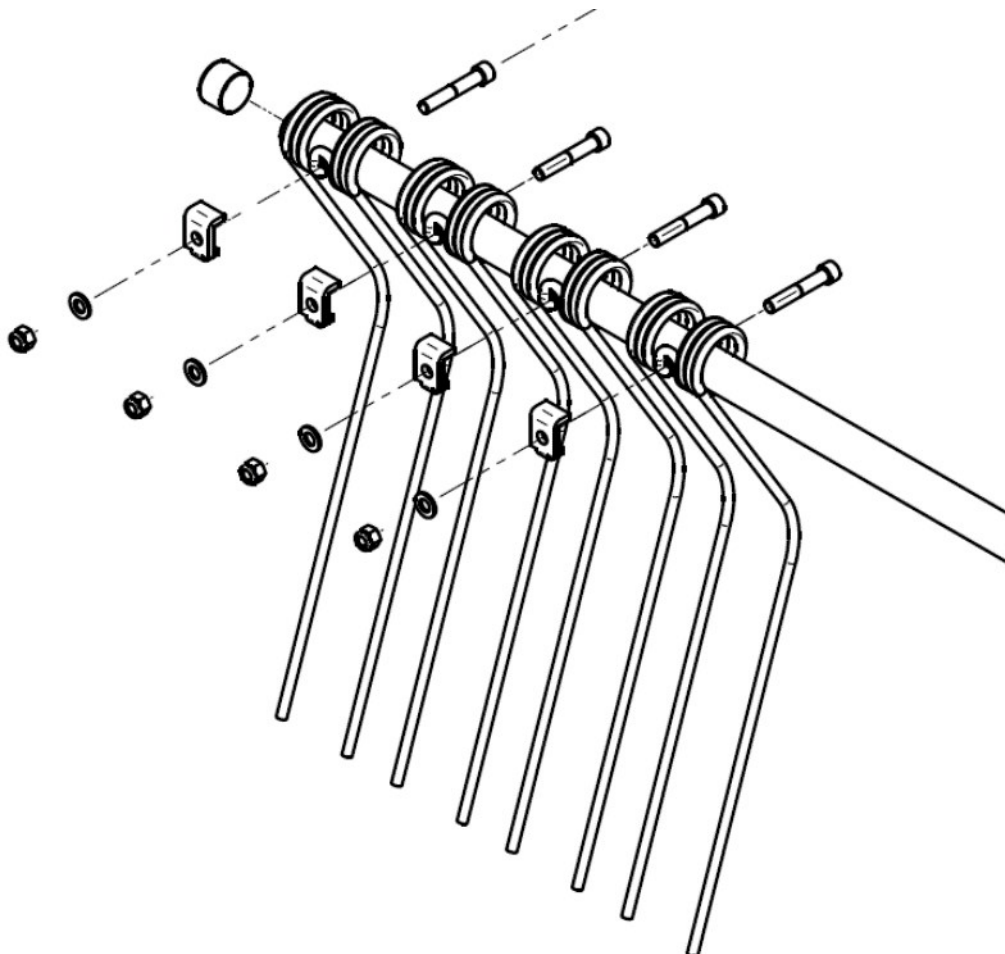

Figure 15. Tine arm

Lubrication and Maintenance

7.2 Post-operation maintenance

Each time after work, the machine should be thoroughly cleaned, washed with a stream of running water and set on a flat, hard surface. Review the connections of parts and assemblies.

Replace damaged and worn parts with new ones. Check all bolted connections, and tighten loose ones according to “**Torque Specifications**” on page 44.





7.3 Lubricating the machine

Properly conducted periodic maintenance significantly reduces wear and tear on mating components and further protects against corrosion.

Lubricate all of the lubrication points listed below. These operations should be carried out using a grease gun for solid lubricants. Before starting lubrication, clean the lubrication area of dirt and residues of previously used grease and check the condition of the grease nipple for damage. If damage is found, replace with a working one. After lubrication, remove excess grease to reduce dust adhesion. In addition, there is SAE90EP oil in the mechanical transmission and only such oil should be used. The first oil change must be done after the first 50 hours worked. Subsequent replacements should be made after 400h of operation at least once a year before the season. There is a filler plug on the top body of the gearbox, which also serves as an oil level indicator. The drain plug is located at the bottom of the body. Check systematically before each use of the rake for oil leaks from the gearbox. If a leak is found, the leak must be repaired immediately and the oil refilled to the required volume. Repair of the gearbox during the warranty period can only be performed by specialized mechanical workshops.

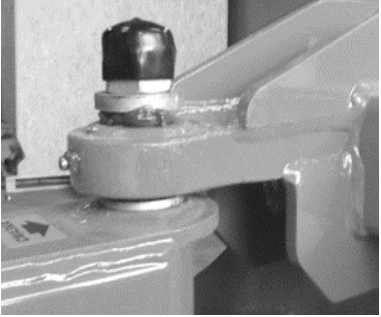
Lubrication and Maintenance

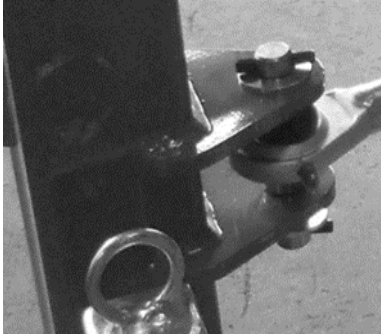
Lubrication and service intervals

Item	Greasing Points	Description	Service intervals	Type of grease
1		Main pivot pin socket	10 hours	Solid grease
2		Roller bushing - main pivot pin	10 hours	Solid grease
3		Steering rod connection at the headstock	10 hours	Solid grease
4		Steering rod connection at the main frame	10 hours	Solid grease

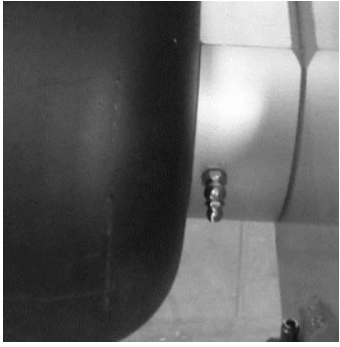
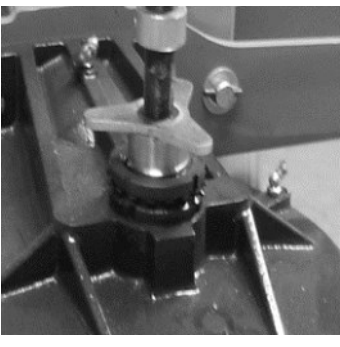
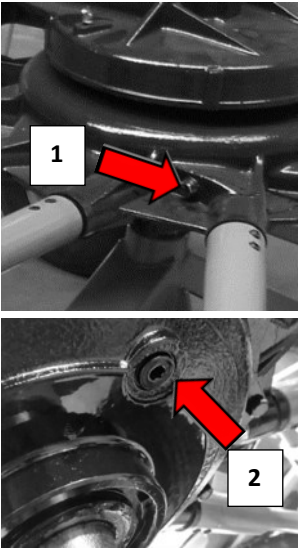

Lubrication and Maintenance

Lubrication and service intervals

Item	Greasing Points	Description	Service intervals	Type of grease
5		Lower linkage pin	10 hours	Solid grease
6		Driveline main bearing	10 hours	Solid grease
7		Gearbox bearings Screw rod height adjustment mechanism	20 hours 50 hours	Solid grease
8		Gearbox oil chamber 1 = Oil filter plug 2 = Oil drain plug	400 hours or once a year	SAE90EP oil 2.8 to 3.0dm ³

Lubrication and Maintenance

Lubrication and service intervals

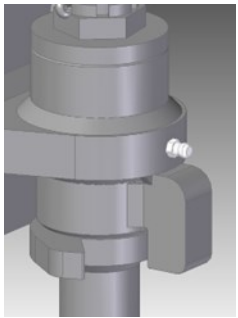
Item	Greasing Points	Description	Service intervals	Type of grease
9		Main axis bushing	50 hours	Solid grease
10		Bogey axles	20 hours	Solid grease
11		PTO shaft	Refer to PTO manual for recommendation	Solid grease
12		Support wheel	20 hours	Solid grease

Lubrication and Maintenance

7.4. Post-season maintenance

After work, the machine should be thoroughly cleaned and washed with a stream of running water. When using high-pressure generating equipment, be careful and do not direct the jet directly on any kind of stickers placed on the machine and on components such as bearings, shaft joints, etc. It is recommended that cleaning and washing of the machine be carried out in a car wash equipped with a sewage treatment plant or a settling tank for neutralization of the resulting sewage.

After washing and drying, inspect the general technical condition of all components and, if necessary, correct the defect found or replace the worn component with a new one. If the paint coating is damaged, mechanically remove the residue of the old paint, degrease then apply a coat of primer and after it dries apply the actual paint coating. It is recommended that the machine be stored in a closed and covered room to reduce environmental factors that cause corrosion and aging of any plastics. In addition, during long downtimes (such as the winter period), it is recommended to lubricate with fresh grease all moving joints and the pull screw of the rake height adjustment mechanism. In addition, using widely available silicone-based anti-corrosive agents, coat the surface of bolts and pins to inhibit corrosion. In addition, tires should be protected from UV rays about 2-3 times during the year by spraying widely available tire preservatives.

When not in use for a long period of time, move the machine slightly to reposition the tire so that it does not become permanently deformed, and additionally check the tire pressure. This activity should be carried out on average once per month.

Disassembly, Disposal, Environmental Protection

8. Disassembly, disposal and environmental protection

In the event the machine is worn to the extent which prevents its further use, it should be scrapped. This also applies to regular repairs and replacement of damaged parts. Clean the machine thoroughly before scrapping. Drain oil from the machine and have the machine decommissioned. Next, disassemble the machine by segregating its parts based on the applied materials. Segregated parts should be transported to a scrap yard or disposed of.

The machine is 100% environmentally friendly. 98% of the materials used in the production process are recyclable. Worn machine parts must be disposed of in line with the local environment protection regulations. Prevent oil leakage throughout the period of use of the machine, as oil may pollute the environment.

ATTENTION!



Protect your hands (and body) against injuries, and the harmful effects of lubricants and oils. Use personal equipment measures and tools which are in good mechanical condition. Machine elements, which when dismantling can move or rotate, must be properly secured.

Worn or damaged parts removed during repair (disassembly) should be stored in a separate location, with a limited access for persons and animals. Worn out metal parts must be delivered to the scrap metal collection points. Worn out plastics must be delivered to the chemical waste collection (utilization) points.

When filling up or replacing the oil, avoid its spillage. Store the waste oil in sealed containers, and periodically deliver it to the special collection (utilization) points.

ATTENTION!



Abandoned parts or machine components, and spilled oil, may pose a risk of accident, cause an environmental pollution and violate applicable laws.

PTO Driveline Instructions

Instructions for Installing a PTO Driveline:

1. Begin by parking the tractor and implement on a level, solid surface. Attach the implement to the tractor's hitch arms, upper and lower. Adjust the tractor's 3-point hitch so that the tractor's output shaft is level with the implement's input shaft.
2. Leave the tractor in gear, shut off the tractor engine, remove the key and set the park brake. Block the implement to prevent it from falling over or shifting.
3. Slide the inner yoke of the PTO shaft 'A' (implement end) onto the input shaft of the implement. Make sure the yoke is securely locked in place.
4. Slide the outer yoke of the PTO shaft 'B' (tractor end) onto the tractor input shaft. Make sure the yoke is securely locked in place.
5. Because of differences in tractor 3-point arms and implements, it may be necessary to shorten the PTO Driveline. See next page for **"Instructions for Shortening a PTO Driveline"**.
6. Check that the PTO Driveline yokes are securely attached to the tractor and implement before operating. PTO Drivelines not attached properly can cause serious injury or death!
7. If your PTO Driveline shields are equipped with chains, secure the chain to the tractor and or implement to prevent the shield from rotating.
8. Before starting tractor and engaging the PTO Driveline, make certain there are no people or animals between tractor and implement. Rotating PTO Drivelines can cause serious injury or death!

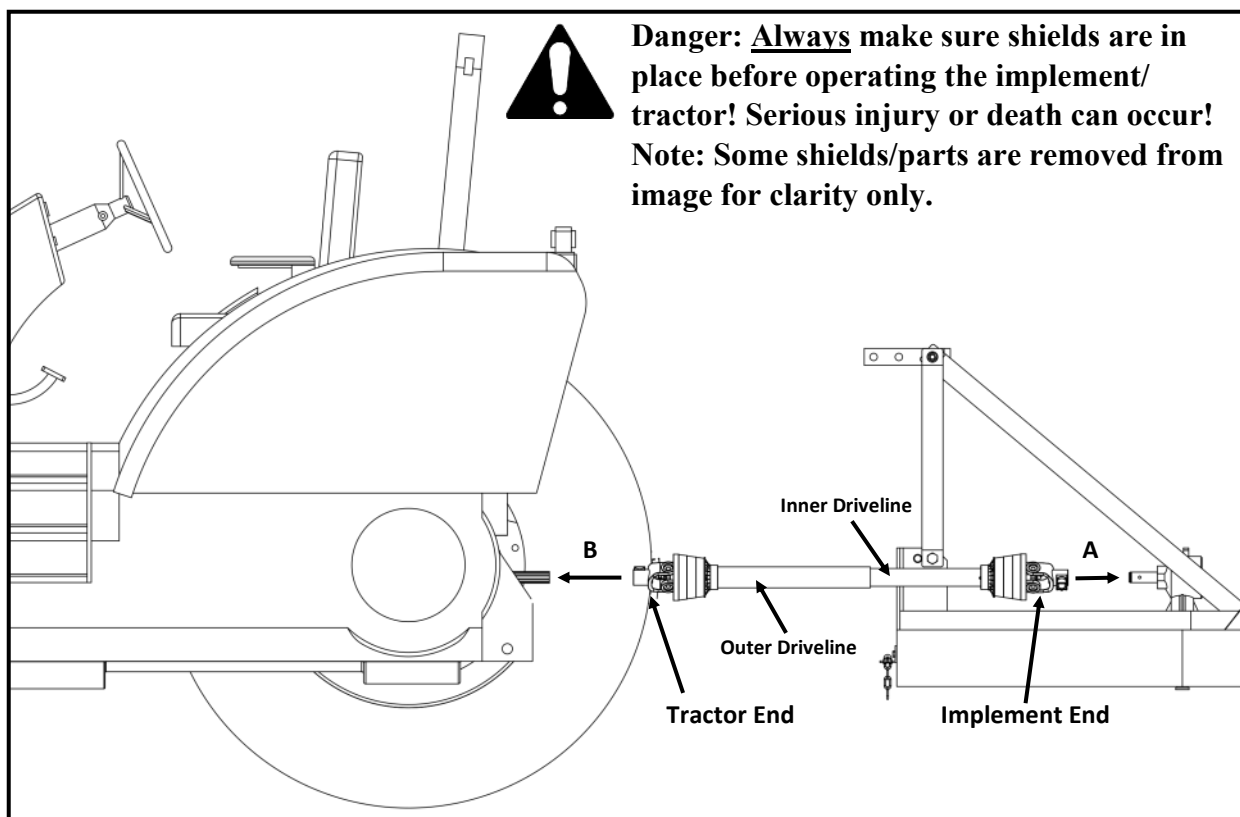

PTO Driveline Instructions

Instructions for Shortening a PTO Driveline:

Note: If you are not confident modifying the PTO Driveline, you should contact a Qualified Professional.

1. Separate the inner and outer PTO Drivelines. Leave separated at this time.
2. Attach the outer PTO Driveline to the tractor implement input shaft and inner PTO driveline to the implement input shaft.
3. With the drivelines parallel to one another, measure 1" (dim. 'B') back from the outer PTO Driveline shield (see fig. 2) and make a mark on the inner PTO Driveline.
4. Measure 1" (dim 'B') back from the inner PTO Driveline shield (see fig. 2) and make a mark on the outer PTO Driveline.
5. Remove the drivelines from the tractor and implement.
6. Measure from the end of the inner shield to the scribed mark (dim. "C"). Cut the inner shield at that mark. Cut the same amount off the inner shaft (dim. "C1").
7. Measure from the end of the outer shield to the scribed mark (dim. "D"). Cut the outer shield at that mark. Cut the same amount off the inner shaft (dim. "D1").
8. Clean off all burrs from both drivelines.
9. Refer to "Checking PTO Driveline Extended Length" section next.

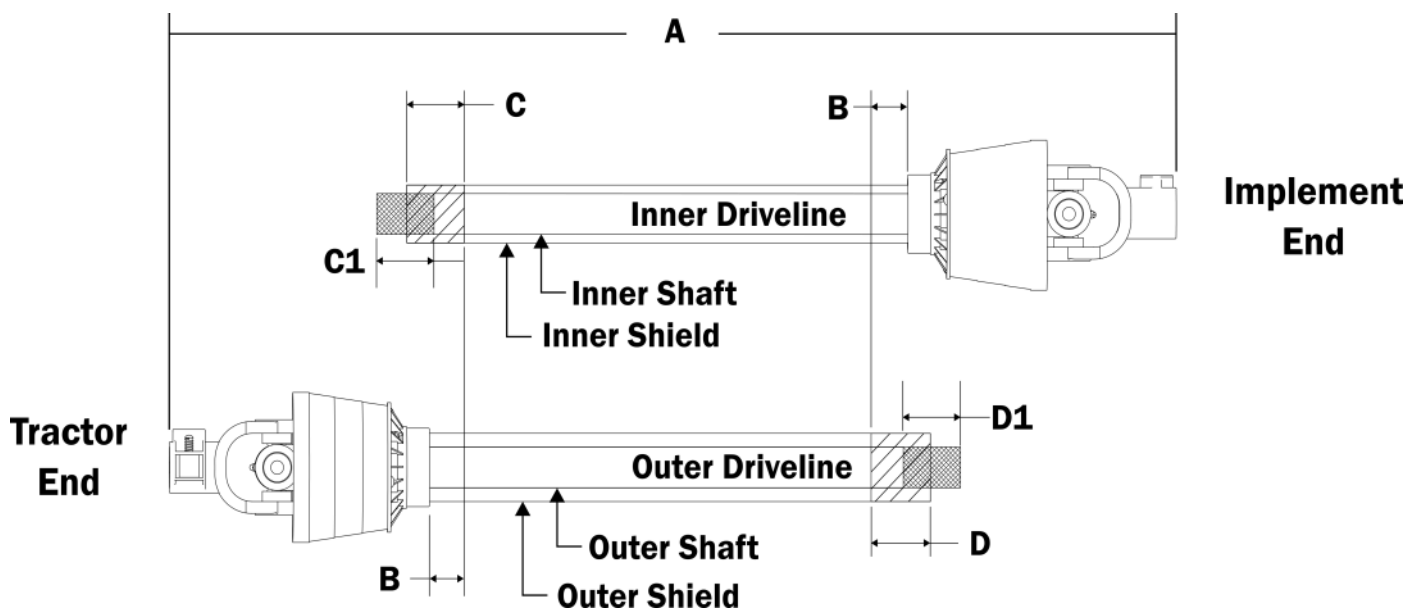

PTO Driveline Instructions

Checking PTO Driveline Extended Length:

1. Apply multi-purpose grease to the outside of the inner driveline section. Assemble the outer and inner drivelines.
2. When fully extended, the maximum allowable length must have a minimum overlap of $\frac{1}{3}$ the free length of the inner and outer sections. Measure and record the maximum extended length for future reference.
3. Attach the outer PTO Driveline to the tractor implement input shaft and inner PTO driveline to the implement input shaft.
4. Pull both yoke ends to make sure they are properly seated on the input shafts. **Warning:** If the drive lines are not properly seated, they can separate from the tractor or implement, causing extensive damage and possibly serious injury or death.
5. Raise and lower the implement to determine the maximum extended length. Make sure the maximum extended length does not exceed the maximum length determined from step 2.

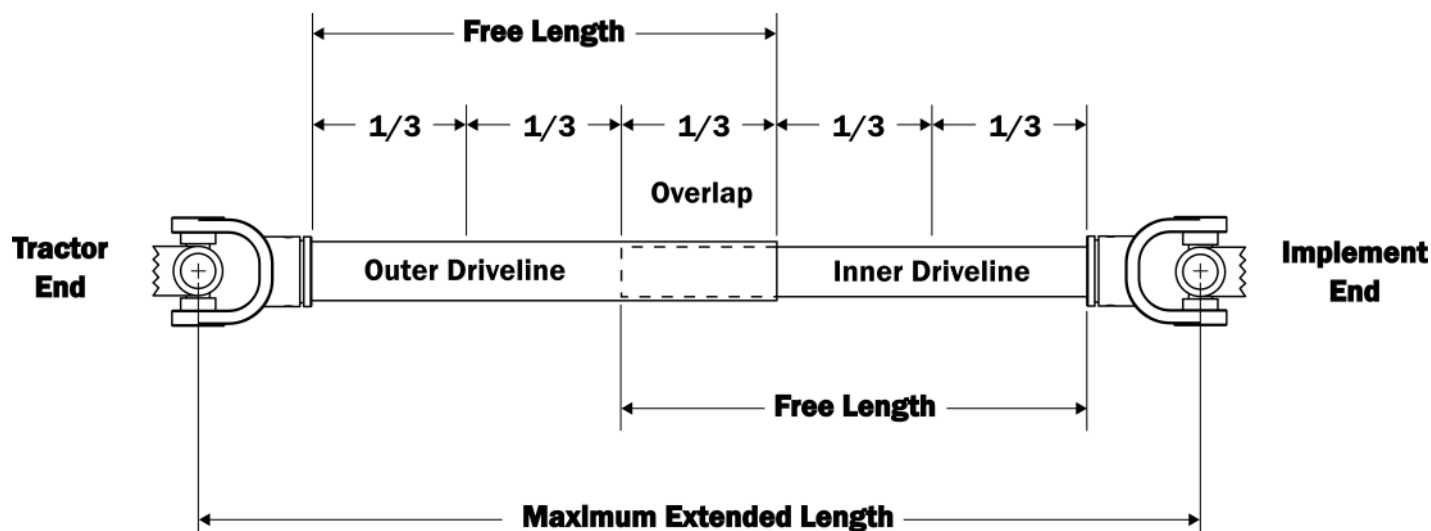

Danger: Always make sure shields are in place before operating the implement/tractor! Serious injury or death can occur!

Note: Some shields/parts are removed from image for clarity

PTO Driveline Instructions

Checking for PTO Driveline Interference:

1. Begin with the PTO Driveline level (0 degrees). Raise the implement at an angle no greater than 25 degrees from level. Check for any interference and the length of the PTO Driveline extended. Do not exceed the maximum extended length!
2. Next lower the PTO Driveline at an angle no greater than 25 degrees from level. Check for any interference and the length of the PTO Driveline extended. Do not exceed the maximum extended length!

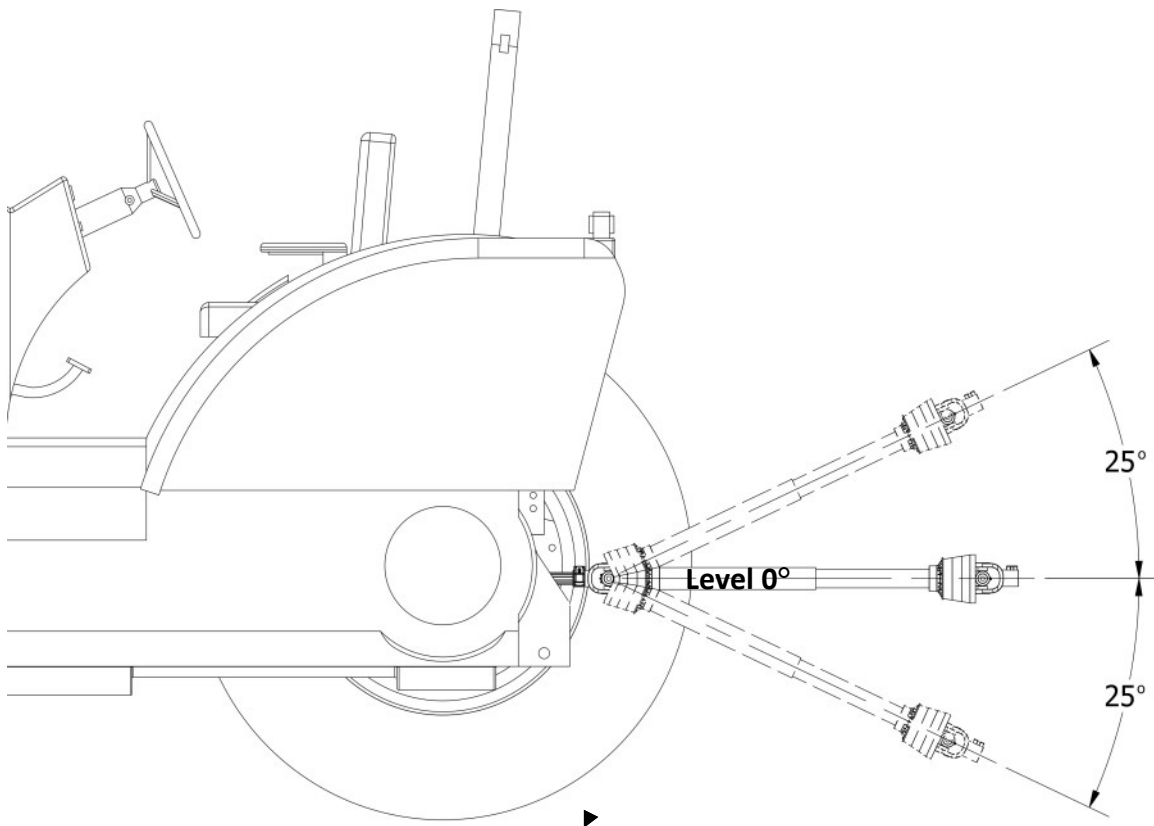

Danger: Always make sure shields are in place before operating the implement/tractor! Serious injury or death can occur!

Note: Some shields/parts are removed from image for clarity

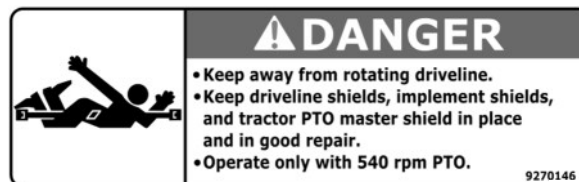

Scan the QR code below for more detailed information on PTO installation.



Torque Specifications

Torque Specifications for Common Bolt Sizes															
Inches		Bolt Head Identification						Metric		Bolt Head Identification					
										5.8		8.8		10.9	
Bolt size (inches)	Thread pitch	Grade 2		Grade 5		Grade 8		Class 5.8		Class 8.8		Class 10.9			
		N.m	ft-lb	N.m	ft-lb	N.m	ft-lb	N.m	ft-lb	N.m	ft-lb	N.m	ft-lb		
1/4"	20	7	5	11	8	16	12	M5	0.08	4	3	6	4	9	7
1/4"	28	8	6	13	10	19	14	M6	1	6	4	10	7	15	11
5/16"	18	15	11	24	17	33	25	M8	1.25	16	12	25	18	36	27
5/16"	24	17	13	26	19	37	27	M8	1	17	13	26	19	38	28
3/8"	16	27	20	42	31	59	44	M10	1.5	31	23	48	35	71	52
3/8"	24	31	23	47	35	67	49	M10	1.25	33	24	51	38	75	55
7/16"	14	43	32	67	49	95	70	M10	1	35	26	53	39	78	58
7/16"	20	48	36	75	55	106	78	M12	1.75	54	40	84	62	123	91
1/2"	13	66	48	102	75	144	106	M12	1.5	56	41	87	64	128	94
1/2"	20	75	55	115	85	163	120	M12	1.25	59	44	90	66	133	98
9/16"	12	95	70	147	109	208	154	M14	2	84	62	133	98	195	144
9/16"	18	106	79	164	121	232	171	M14	1.5	94	69	142	105	209	154
5/8"	11	132	97	203	150	287	212	M16	2	131	97	206	152	302	223
5/8"	18	149	110	230	170	325	240	M16	1.5	141	104	218	161	320	236
3/4"	10	233	172	361	266	509	376	M18	2.5	181	133	295	218	421	310
3/4"	16	261	192	403	297	569	420	M18	2	196	145	311	229	443	327
7/8"	9	226	167	582	430	822	606	M18	1.5	203	150	327	241	465	343
7/8"	14	249	184	642	473	906	668	M20	2.5	256	189	415	306	592	437
1"	8	339	250	873	644	1232	909	M20	1.5	288	212	454	335	646	476
1"	12	371	273	955	704	1348	995	M22	2.5	344	254	567	418	807	595
1-1/8"	7	480	354	1077	794	1746	1288	M22	1.5	381	281	613	452	873	644
1-1/8"	12	539	397	1208	891	1958	1445	M24	3	444	327	714	526	1017	750
1-1/4"	7	677	500	1519	1120	2463	1817	M24	2	488	360	769	567	1095	808
1-1/4"	12	750	553	1682	1241	2728	2012	M27	3	656	484	1050	774	1496	1103
1-3/8"	6	888	655	1992	1469	3230	2382	M27	2	719	530	1119	825	1594	1176
1-3/8"	12	1011	746	2268	1673	3677	2712	M30	3.5	906	668	1420	1047	2033	1499
1-1/2"	6	1179	869	2643	1949	4286	3161	M30	2	1000	738	1600	1180	2250	1659
1-1/2"	12	1326	978	2974	2194	4823	3557	M36	4	1534	1131	2482	1830	3535	2607

Notes:

This chart is an approximate estimate of torque values.

Always tighten hardware to these values unless a different torque value or tightening procedure is listed for a specific application.

Fasteners must always be replaced with the same grade as specified in the manual.

Always use the proper tool for tightening hardware: SAE for SAE hardware and Metric for Metric hardware.

Page left blank intentionally



Rotary Rake

ZGR-360

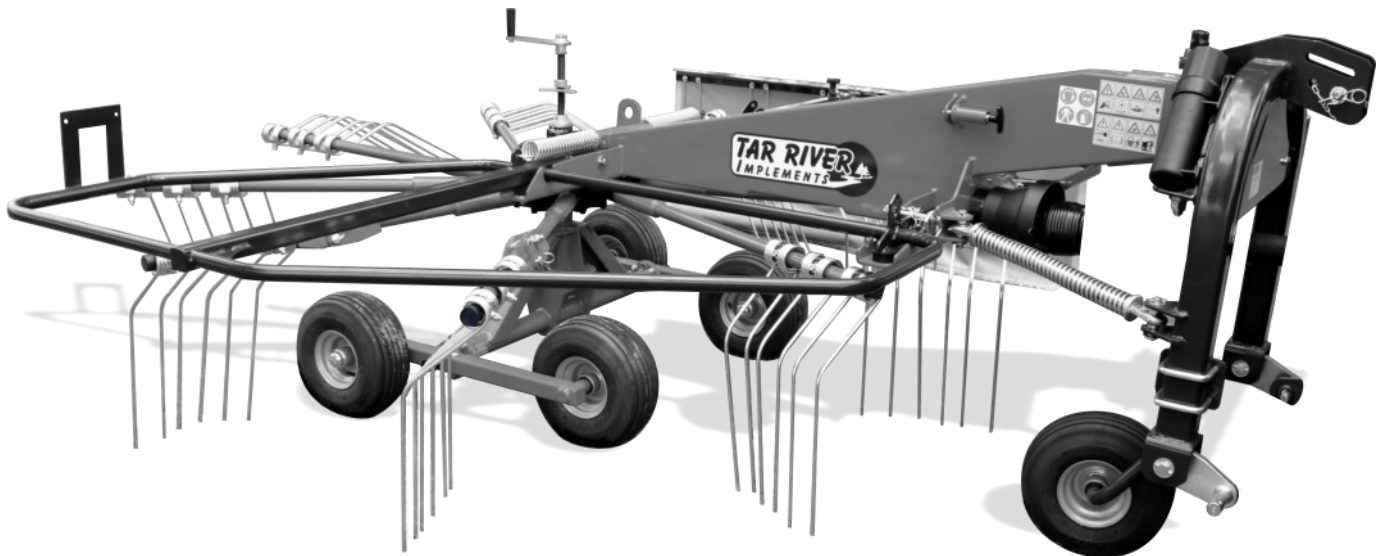

Parts Manual

Rel. 09/24

Main Hitch

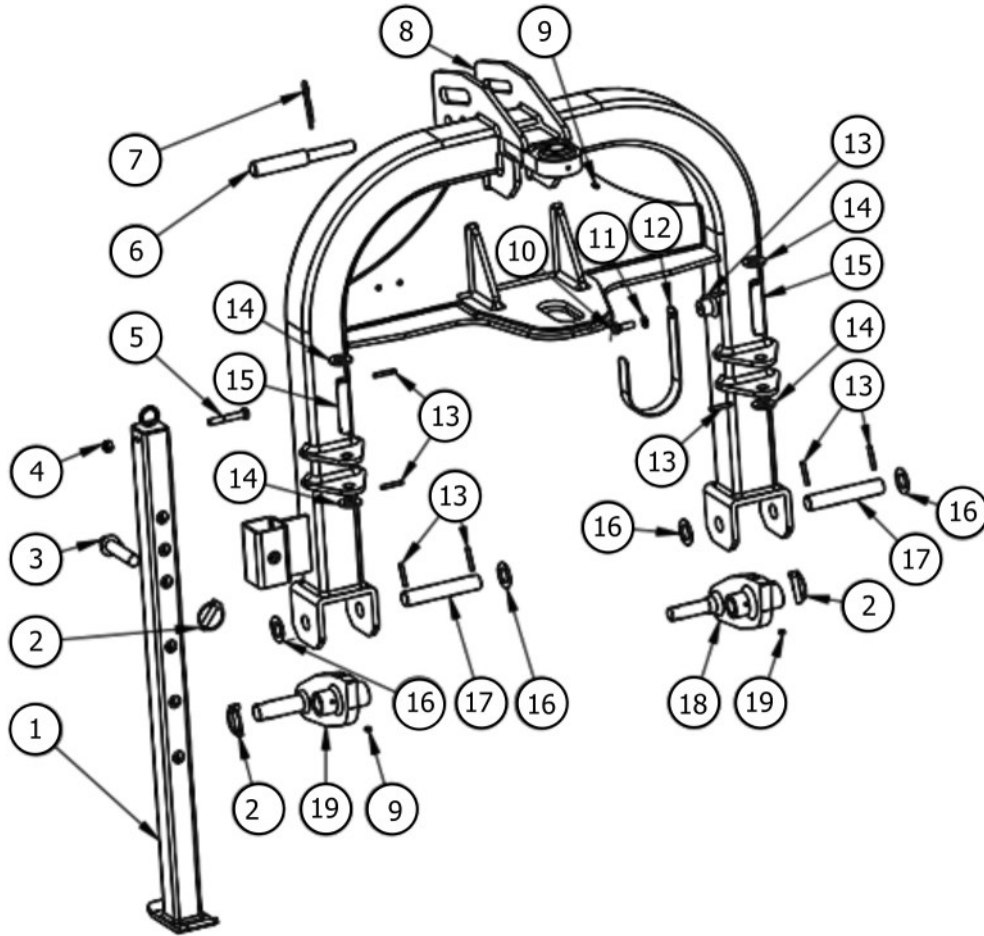

Main Hitch

Item	Part #	Description	Qty.
1	ZGR10069	Support foot	1
2	ZGR10168	Safety pin	3
3	ZGR10084	Lock pin	1
4	LN1015	Self-locking nut M10 galv.	1
5	BM101560	Bolt M10-1.5x60-8.8 galv.	1
6	ZGR10030	Upper hitch pin	1
7	ZGR10171	Cotter pin 4x100	2
8	ZGR10028	Hitch frame	1
9	GN061S	Grease fitting - M6x1 straight	1
10	BM101525	Bolt M10x25-8.8 galv.	1
11	FW10	M10 OC DIN 125 plain washer	1
12	ZGR10029	PTO shaft mounting	1
13	RP06X40	Spring pin 6x40	8
14	FW20	Plain washer M20 OC DIN 125	4
15	ZGR10065	Steering arm pin	2
16	ZGR10036	Washer fi44 / fi25.5	4
17	ZGR10037	Lower suspension pin	2
18	ZGR10035	Right lower link	1
19	ZGR10038	Left lower link	1

Main Frame

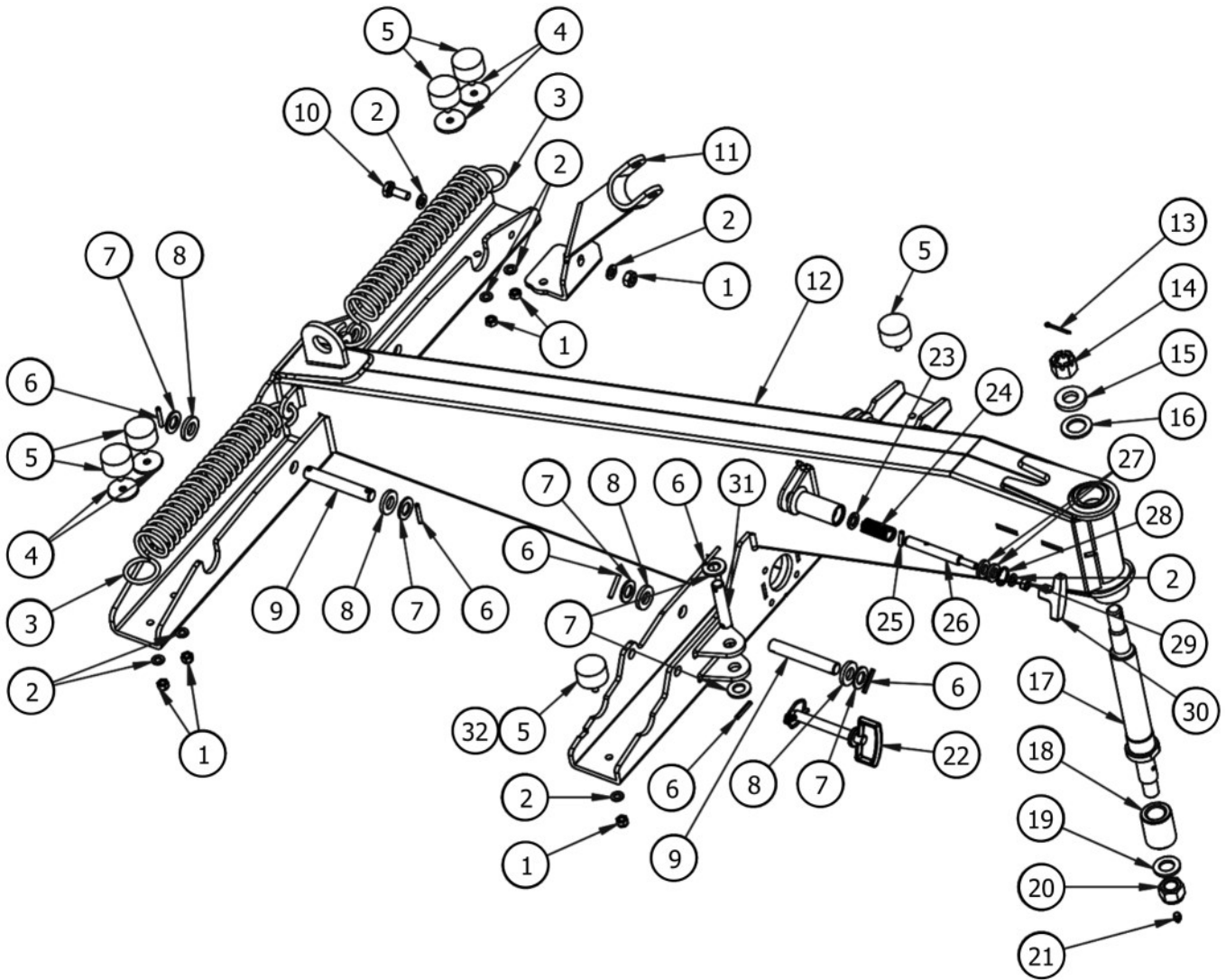

Main Frame

Item	Part #	Description	Qty.
1	LNM1015	Self-locking nut M10 galv.	5
2	FW10	M10 OC DIN 125 plain washer	8
3	ZGR10147	Tension spring 7x60x250	2
4	ZGR10063	Rubber buffer washer 5028 D70	2
5	ZGR10163	Vibration damper type D 5028.D70	2
6	RP6X40	Expansion pin 6x40	12
7	FW20	Plain washer M20 OC DIN 125	16
8	ZGR10062	Barrier pin washer	2
9	ZGR10065	Barrier pin	4
10	BM101535	Bolt M10x35-8.8 galv.	1
11	ZGR10040	Arm rotation lock	1
12	ZGR10070	Main frame	1
13	CP5X40	Split pin 5x40 galv.	1
14	ZGR10101	M24 crown nut galv.	1
15	CNM2415	Washer under the M24x1.5 crown nut	1
16	ZGR10032	Main corner pin washer	2
17	ZGR10031	Main corner pin	1
18	ZGR10034	Main pin sliding bush	2
19	FW25	Plain washer M25 OC DIN 125	4
20	LNM2430	Self-locking nut M24 galv.	1
21	GN1015	Grease fitting - M10x1.0 straight	1
22	ZGR10185	Pin with a handle 16x112 mm	1
23	ZGR10043	Thrust washer	1
24	ZGR10146	Compression spring Ø25 L70Ø2 80.005.044	2
25	ZGR10093	Spring pin 6x25	2
26	ZGR10041	Bolt pin	2
27	ZGR10042	Spacer	4
28	SRI30	Circlip W30	2
29	NM1015	Nut M10 galv.	2
30	ZGR10164	Handle 652/80 M10	2
31	ZGR10065	Steering arm pin	2
32	ZGR10086	Vibration damper 5021D55	2

Driveline

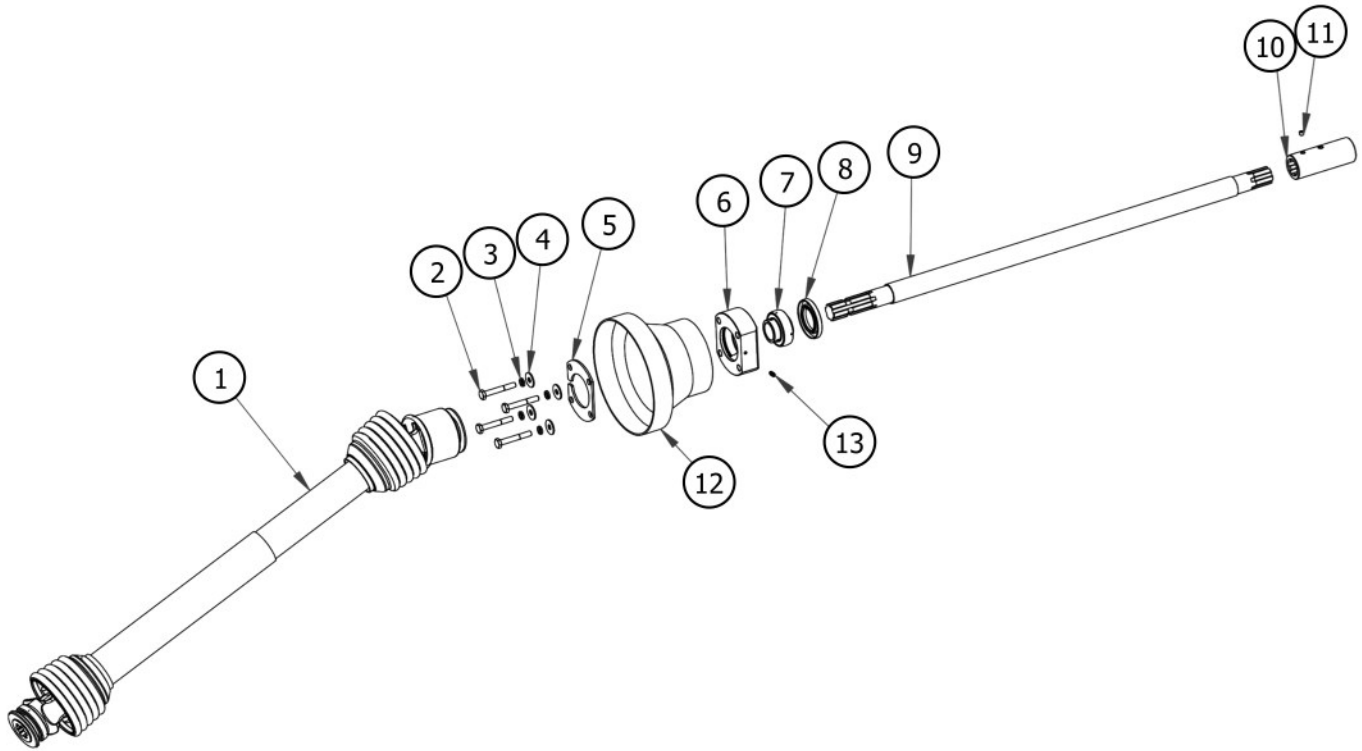

Item	Part #	Description	Qty.
1	ZGR10166	PTO shaft - 270 Nm with M34 ratchet clutch	1
2	BM101570	Bolt M10x70-8.8 OC DIN 931 partial thread	4
3	LW10	Spring washer M10 OC	4
4	LFW10	M10 OC DIN 9021 enlarged washer	4
5	ZGR10044	PTO Shield mounting plate	1
6	ZGR10045	Bearing housing	1
7	BUC207	UC 207 bearing	1
8	ZGR10165	TC sealant 48x80x10	1
9	ZGR10071	Spline shaft L = 1195mm	1
10	ZGR10046	L-130mm splined bushing	1
11	ZGR10167	Socket screw M8x8	1
12	ZGR10116	PTO guard	2
13	GN061S	Grease fitting - M6x1 straight	1

Control Arm

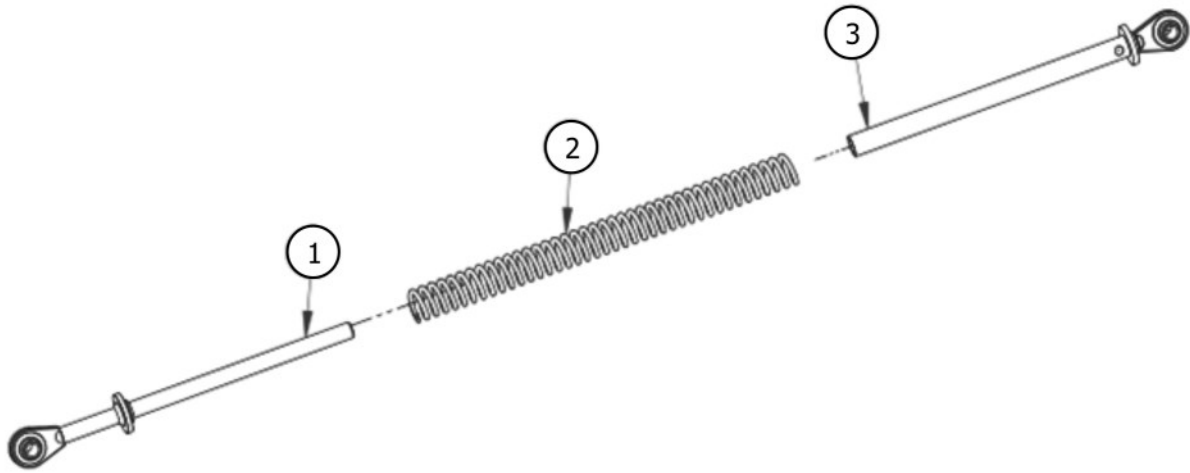

Item	Part #	Description	Qty.
1	ZGR10079	Internal link control arm	2
2	ZGR10175	Compression spring 550x50x7x15	2
3	ZGR10078	External link control arm	2

Protective Barriers

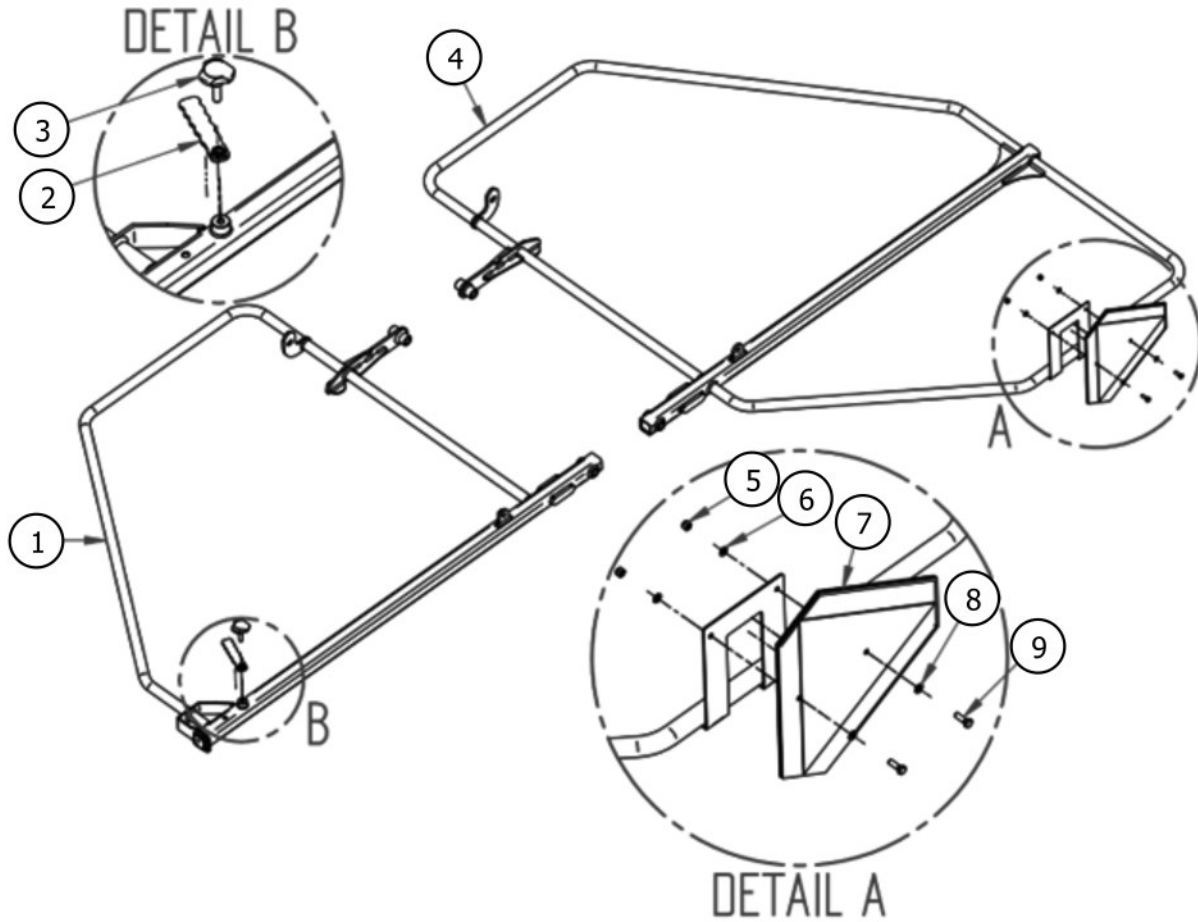

Item	Part #	Description	Qty.
1	ZGR10076	Protective barrier - swath side	1
2	ZGR10001	Counter lever	1
3	ZGR10184	Cross knob	1
4	ZGR10077	Protective barrier - side of reflective plate	1
5	LNLM08125	Self-stop nut M8 galv.	2
6	FW08	Plain washer M8 OC DIN 125	2
7	ZGR10161	SMV sign	1
8	LFW08	Enlarged washer M8 OC Din 9021	2
9	BM0812520	Bolt M8x20-8.8 OC DIN 933	2

Swath Screen

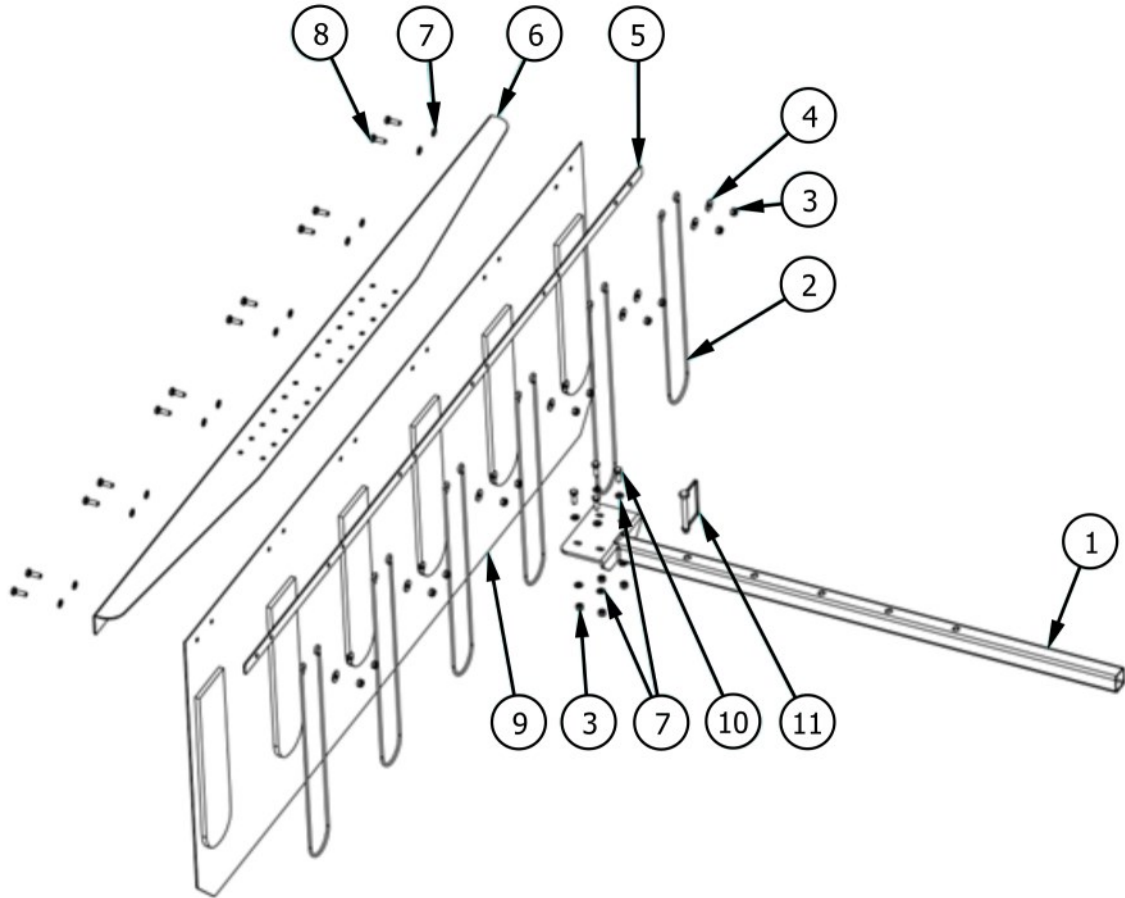

Item	Part #	Description	Qty.
1	ZGR10080	Swath screen arm	1
2	ZGR10087	Stiffening element 500x84x5	6
3	LN08125	M8 self-stop nut	16
4	LF08	Enlarged washer M8 OC Din 9021	12
5	ZGR10067	Fastening bar	1
6	ZGR10068	Apron mount	1
7	FW08	Plain washer M8 OC DIN 125	20
8	BM0812525	Bolt M8x25-8.8 OC	4
9	ZGR10088	Apron 5272/512-05-202	1
10	BM0812530	Bolt M8x30-8.8 OC	12
11	ZGR10172	Folding pin 12x67	1

Raking Height Adjustment

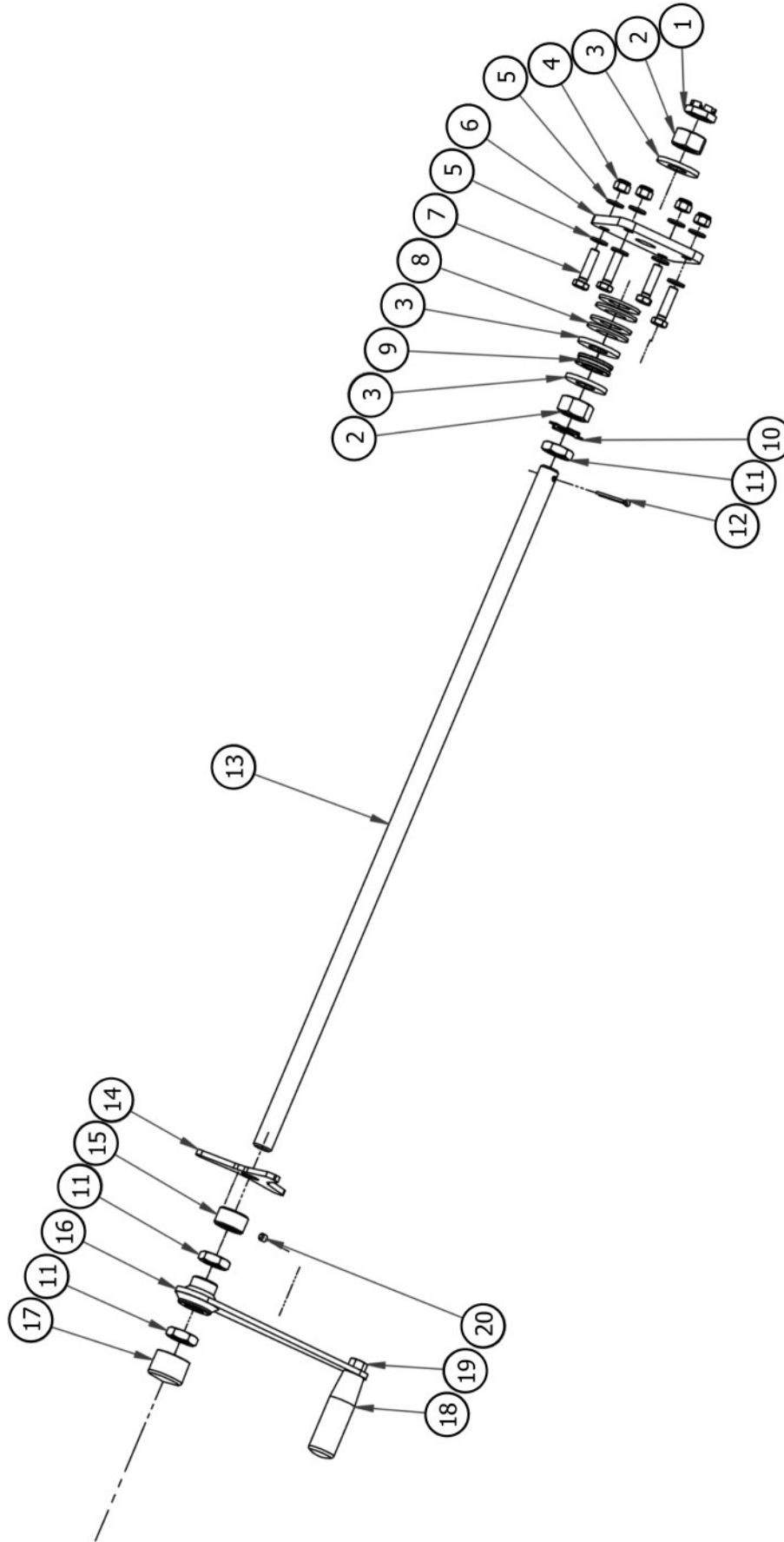

Raking Height Adjustment

Item	Part #	Description	Qty.
1	CNM2215	Lock nut low M22-1.5 oc	1
2	NM2215	Nut M22-1.5 galv.	1
3	ZGR10055	Washer	3
4	LNM1015	Self-locking nut M10 galv.	4
5	FW08	M10 OC DIN 125 plain washer	8
6	ZGR10053	Fastening plate	1
7	BM101535	Bolt M10x35-8.8 galv.	4
8	ZGR10148	Disc spring DIN2093 50x25,4x3	4
9	ZGR10097	Thrust bearing 51105	2
10	ZGR10051	Wing washer	2
11	ZGR10104	Low nut M22x1.5 galv.	3
12	CP5x40	Split pin 5x40 galv.	1
13	ZGR10050	Lead screw	1
14	ZGR10052	Lock nut	1
15	ZGR10054	Lead screw extension limiter	1
16	ZGR10049	Crank	1
17	ZGR10111	Flexible cap 34.9 x 38	1
18	ZGR10099	Handle 280/100 P M10 (22111)	1
19	ZGR10108	Self-locking nut M12 OC DIN 985	1
20	ZGR10167	Socket screw M8x8	1

Main Gearbox

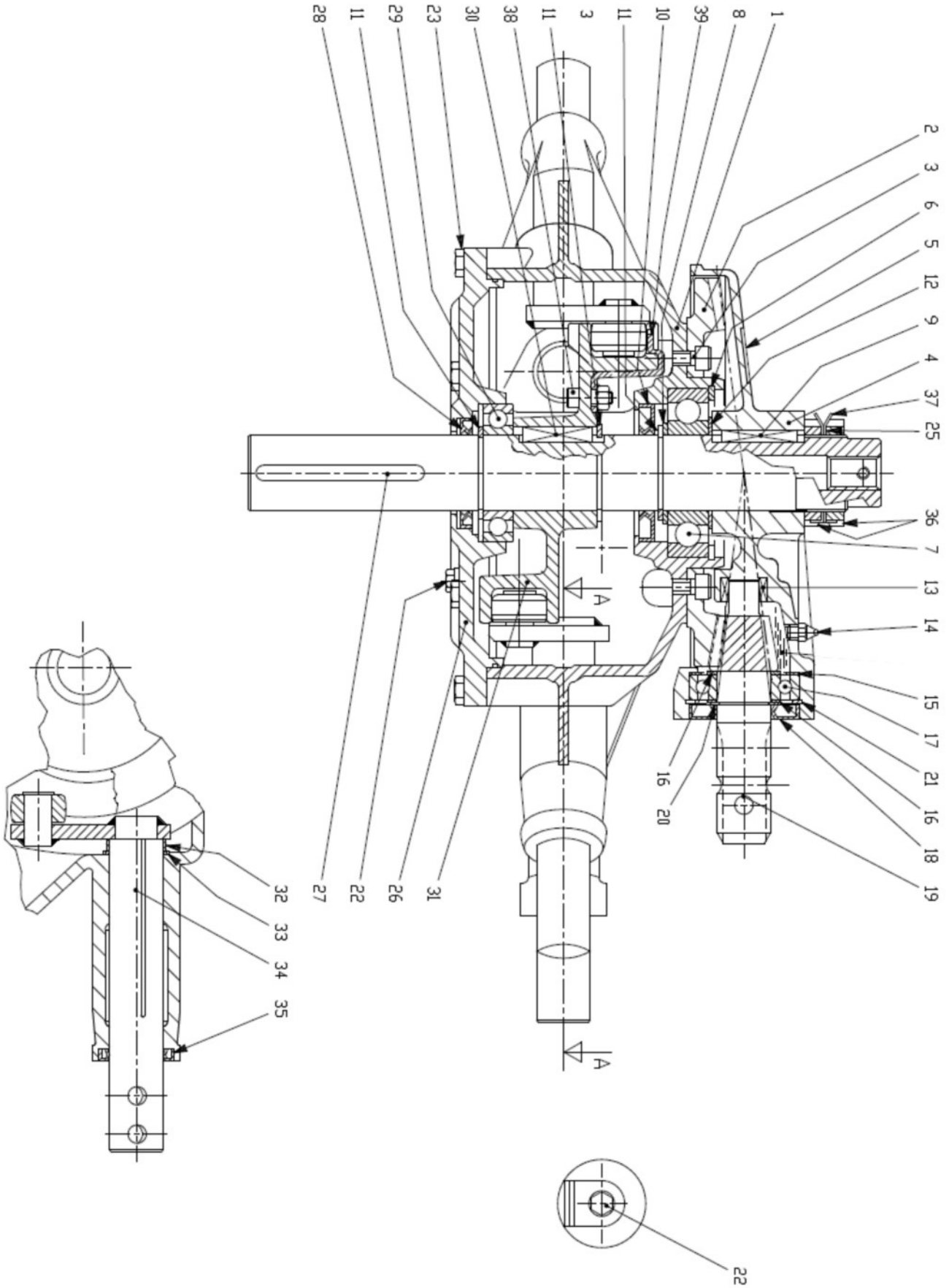

Main Gearbox

Item	Part #	Description	Qty.
1	ZGR10237	Casing - gearbox, ZGR-360	1
2	ZGR10238	Crown wheel Z72 M3.55	1
3	ZGR10239	Bolt M10x16 8.8 Driloc	8
4	ZGR10240	Cover - gearbox, ZGR-360	1
5	ZGR10199	Plate - gearbox, ZGR-360	1
6	ZGR10200	Snap ring 110UNI7437	1
7	ZGR10224	Bearing 6310	1
8	ZGR10205	Shim 50.3x2.5	1
9	ZGR10229	Parallel key B 10x8x50	1
10	ZGR10241	Double lip seal 50x90x10	1
11	ZGR10262	Snap ring 50 UNI7436	3
12	ZGR10201	Shim 70.3	1
13	ZGR10242	Needle bearing 20x26x16	1
14	ZGR10243	Grease nipple M10x1.5	1
15	ZGR10244	Shim 49x71.7x0.2	1
16	ZGR10245	Shim 35.3x48.0	2
17	ZGR10246	Bearing 6207	1
18	ZGR10247	Oil seal 35x72x10	1
19	ZGR10248	Pinion shaft Z10 M3.55	1
20	ZGR10249	Snap ring 35 UNI7435	1
21	ZGR10250	Snap ring 72 UNI7437	1
22	ZGR10251	Plug 3/8" gas	2
23	ZGR10252	Bolt M10x25 8.8	10
24			
25	ZGR10236	Shim 2x57.5x0.5	1
26	ZGR10253	Cover - gearbox, ZGR-360	1
27	ZGR10254	Shaft - gearbox, ZGR-360	1
28	ZGR10255	Oil seal 50x72x8	1
29	ZGR10256	Bearing 6210	1
30	ZGR10257	Parallel key B 10x8x35	1
31	ZGR10258	Camme - gearbox, ZGR-360	1
32	ZGR10221	Spacer	9
33	ZGR10235	Shim 40.3x1.0	18
34	ZGR10259	Connecting rod - gearbox, ZGR-360	9
35	ZGR10219	Oil seal 35x45x7	9
36	ZGR10204	Lock nut M50X1,5 H11	2
37	ZGR10203	Spring Washer 50x74x1.25	2
38	ZGR10260	Bolt M10x22 8.8 Driloc	1
39	ZGR10261	Nut + sheet plate	1
-	ZGR10136	9-arm gearbox, ZGR-360	1

Raking Arm Folding

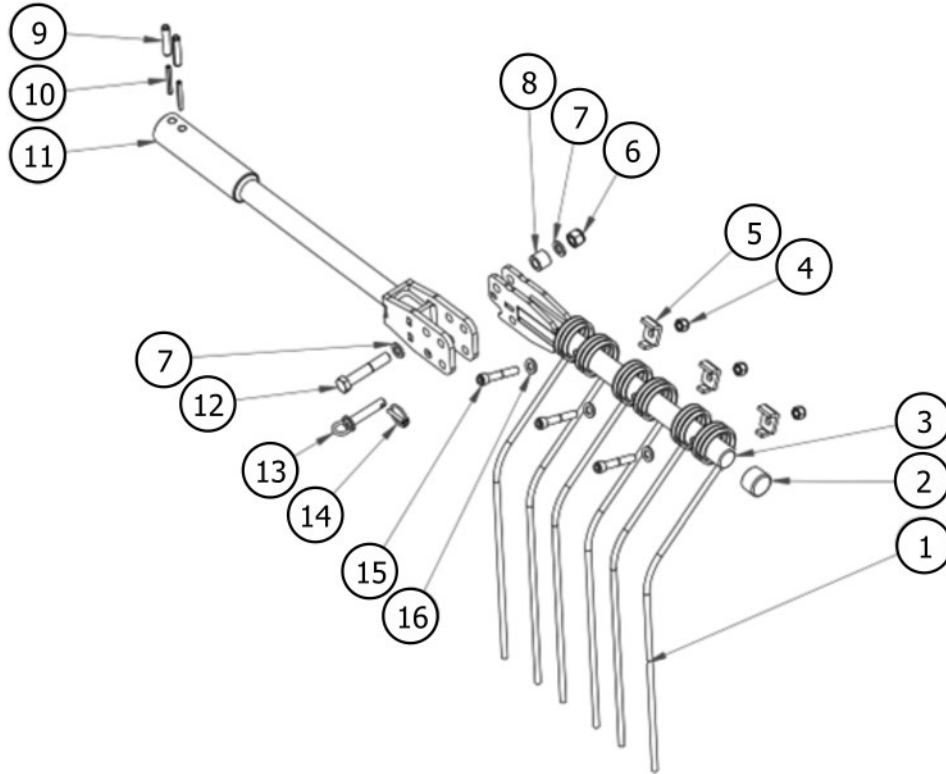

Item	Part #	Description	Qty.
1	ZGR10117	Rake tine	50
2	ZGR10183	Plug	1
3	ZGR10074	Folding arm - raking side	4
4	LN12175	Self-locking nut M12 galv.	3
5	ZGR10057	Tine clamp	100
6	LN1620	Self-locking nut M16 galv.	1
7	FW16	Plain washer M16 OC DIN 125	2
8	ZGR10060	Spacer bushing for arms	1
9	ZGR10090	Roll pin 12x60	2
10	ZGR10092	Roll pin 7x60	2
11	ZGR10075	Folding arm - gearbox side	4
12	BM162090	Bolt M16x90-8.8 OC DIN 931 partial thread	1
13	ZGR10061	Pin for locking folding arms	1
14	ZGR10170	Universal pin OC 6mm	1
15	BM1217580PT	Screw M12-1.75x80-8.8 partial thread	50
16	FW12	Plain washer M12 OC DIN 125	3

Raking Arm Stiff

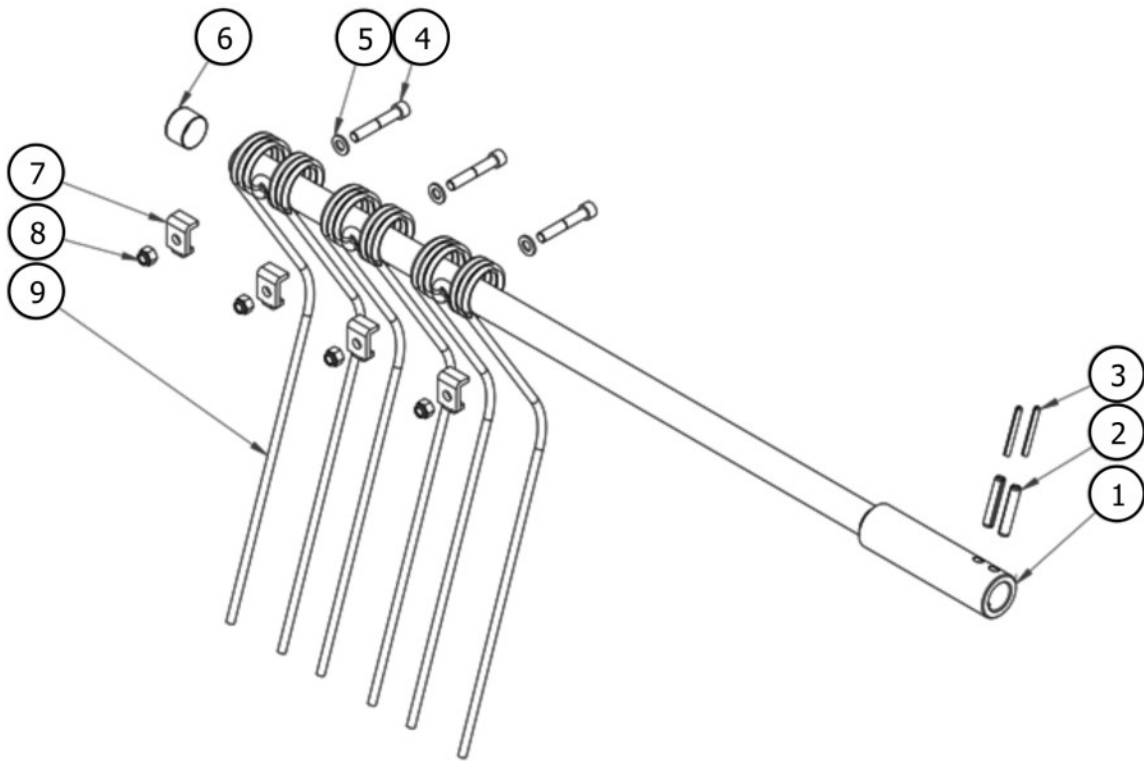

Item	Part #	Description	Qty.
1	ZGR10073	Fixed arm	5
2	ZGR10090	Roll pin 12x60	2
3	ZGR10092	Roll pin 7x60	2
4	BM1217580PT	Screw M12-1.75x80-8.8 partial thread	3
5	FW12	Plain washer M12 OC DIN 125	3
6	ZGR10183	Plug	1
7	ZGR10057	Rake tine fixing	15
8	LNM12175	M12 self-stop nut	15
9	ZGR10117	Rake tine	15

Chassis

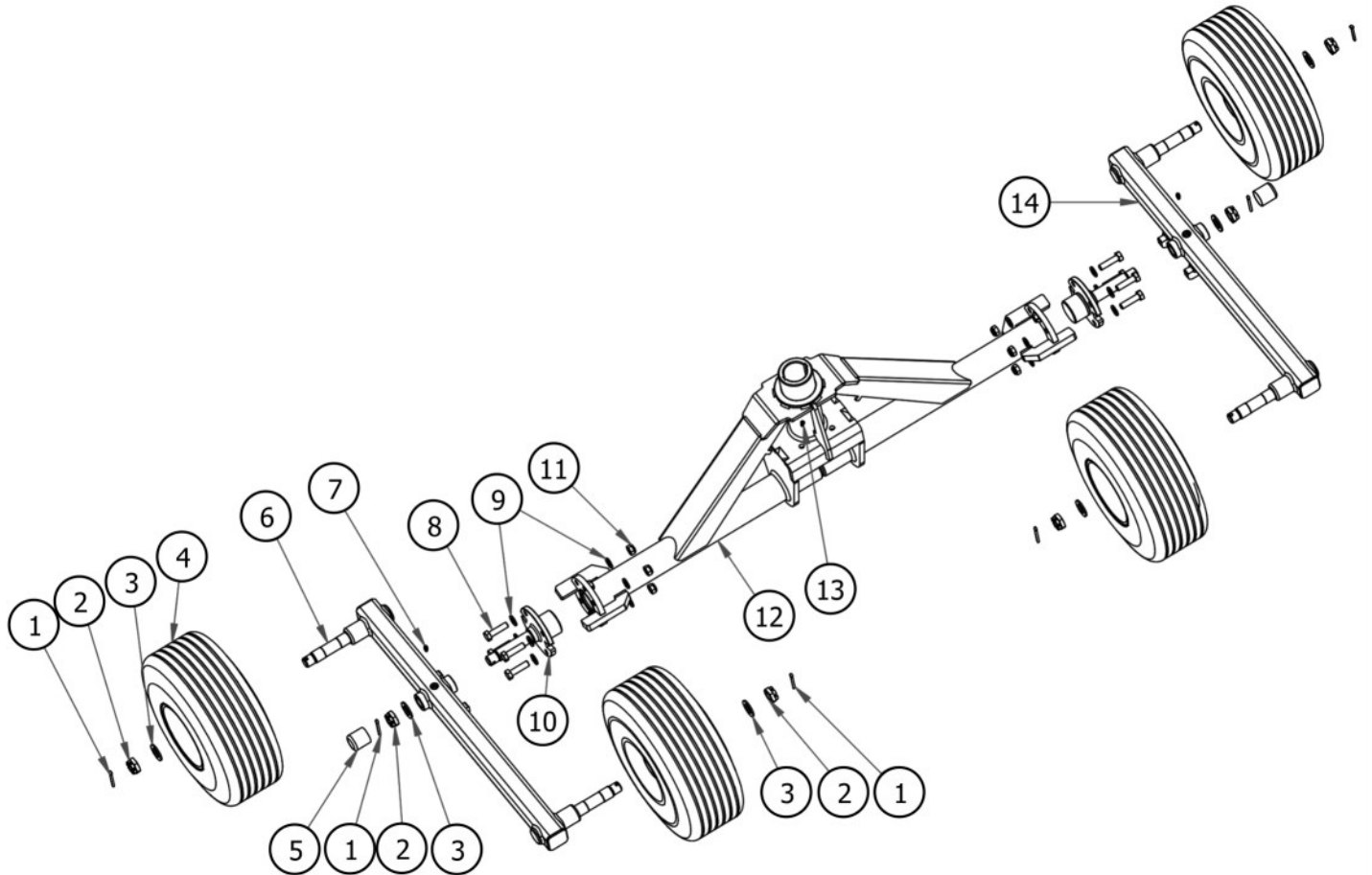

Item	Part #	Description	Qty.
1	CP5x40	Split pin 5x40 galv.	2
2	ZGR10103	Lock nut M22x1.5 galv.	6
3	FW22	Plain washer M22 OC DIN 125	6
4	ZGR10094	Wheel 15x6.00-6 6PR	4
5	ZGR10111	Flexible cap 34.9 x 38	4
6	ZGR10047	Right beam	1
7	GN081S	Grease fitting - M8x1 straight	2
8	BM1217545	Bolt M12x45-8.8 DIN 933	8
9	FW12	Plain washer M12 OC DIN 125	16
10	ZGR10000	Plug	2
11	LNM12175	Self-locking nut M12 galv.	8
12	ZGR10072	Axis	1
13	GN0615	Grease fitting - M6x1 straight	1
14	ZGR10048	Left beam	1

Support Wheel

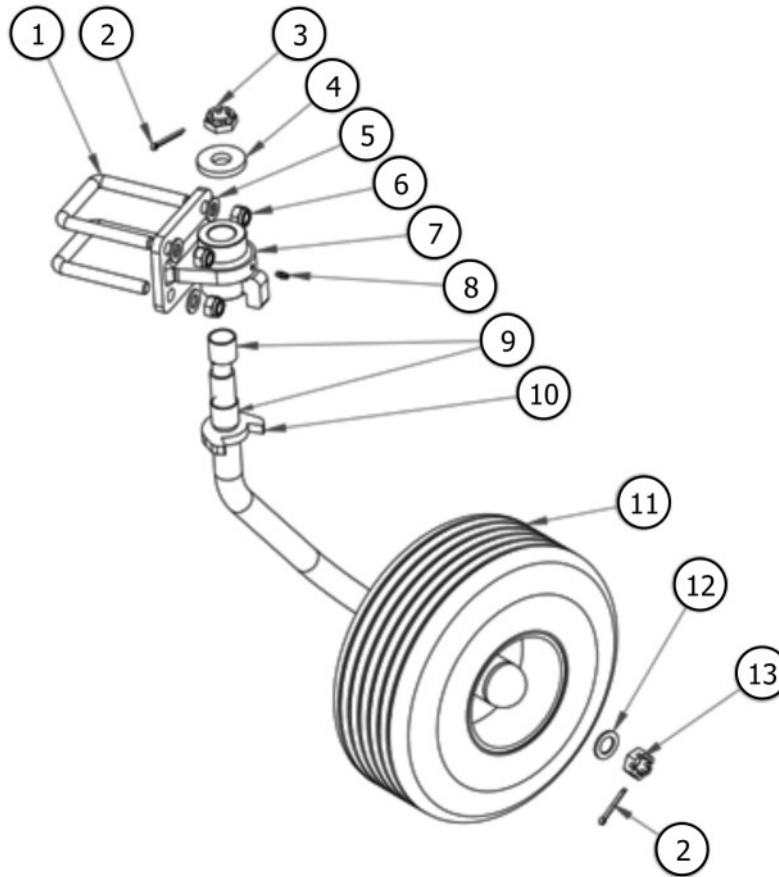

Item	Part #	Description	Qty.
1	ZGR10176	Clamp M16 16x82x135	4
2	CP5x40	Split pin 5x40 galv.	2
3	ZGR10106	Low lock nut M24x1.5 galv.	1
4	ZGR10081	Wheel arm bolt washer	2
5	FW16	Plain washer M16 OC DIN 125	4
6	LN1620	Self-locking nut M16 galv.	4
7	ZGR10082	Wheel arm bracket	1
8	GN0615	Grease fitting - M6x1 straight	1
9	ZGR10098	Sliding bushing PAP 3030-P10	2
10	ZGR10083	Wheel bar	1
11	ZGR10094	Wheel 15x6.00-6 6 PR	1
12	FW22	Plain washer M22 OC DIN 125	1
13	CNM2215	Low lock nut M22x1.5 galv.	1

Warranty

LIMITED WARRANTY

Belco Resources Equipment warrants to the original purchaser of any new piece of machinery from Belco Resources Equipment, purchased from an authorized Belco Resources Equipment dealer, that the equipment be free from defects in material and workmanship for a period of one (1) year for non-commercial, state, and municipalities' use, ninety (90) days for commercial use from date of retail sale. Warranty for rental purposes is thirty (30) days. The obligation of Belco Resources Equipment to the purchaser under this warranty is limited to the repair or replacement of defective parts.

Replacement or repair parts installed in the equipment covered by this limited warranty are warranted for ninety (90) days from the date of purchase of such part or to the expiration of the applicable new equipment warranty period, whichever occurs later. Warranted parts shall be provided at no cost to the user at an authorized Belco Resources Equipment dealer during regular working hours. Belco Resources Equipment reserves the right to inspect any equipment or parts, which are claimed to have been defective in material or workmanship.

This limited warranty does not apply to and excludes wear items such as shear pins, tires, tubes knives, blades or other wear items. Oil or grease is not covered by this warranty.

All obligations of Belco Resources Equipment under this limited warranty shall be terminated if:

- Proper service is not performed on the machine.

- The machine is modified or altered in any way.

- The machine is being used or has been used for purposes other than those for which the machine was intended.

DISCLAIMER OF IMPLIED WARRANTIES & CONSEQUENTIAL DAMAGES

Belco Resources Equipment obligation under this limited warranty, to the extent allowed by law, is in lieu of all warranties, implied or expressed, including implied warranties of merchantability and fitness for a particular purpose and any liability for incidental and consequential damages with respect to the sale or use of the items warranted. Such incidental and consequential damages shall include but not be limited to: transportation charges other than normal freight charges; cost of installation other than cost approved by Belco Resources Equipment; duty; taxes; charges for normal service or adjustment; loss of crops or any other loss of income; rental of substitute equipment, expenses due to loss, damage, detention or delay in the delivery.

REGISTRATION

The online Warranty Registration must be completed in order to qualify for coverage on this Limited Warranty. Visit br-equipment.com, click on "Warranty Registration" and completely fill out the form to register the new piece of equipment.

Page left blank intentionally

Page left blank intentionally

Page left blank intentionally



401 Jeffreys Road
Rocky Mount, NC 27804
www.tarrivermfg.com

Tel: 252-822-7140
Fax: 252-787-5855
Sales@tarrivermfg.com