

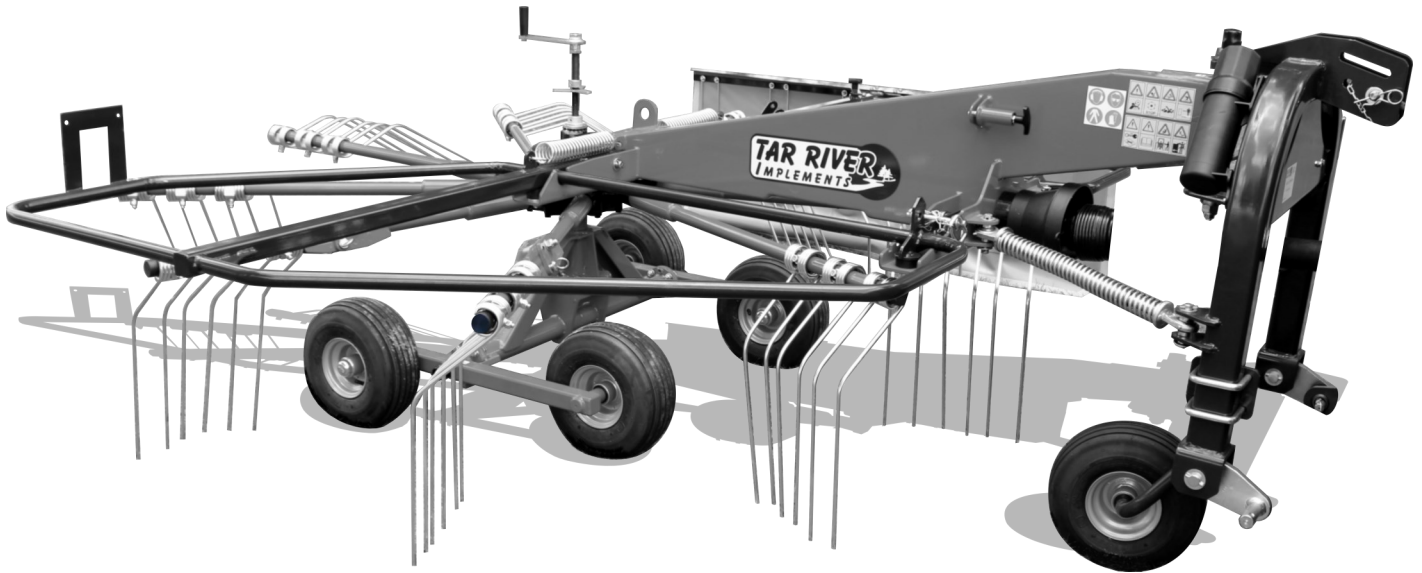

# Rotary Rake

## ZGR-360



# Assembly Instructions

Rel. 08/24

## Rotary rake 3-point hitch - first assembly instruction – BELCO



**ATTENTION:** This document is only a supplement to the full manual which the user is required to read before first use!

### Step 1

Prepare necessary tools:

Drill, impact driver, drill bit PH2, hammer, rubber mallet, metal clippers, wrenches: M13 – 1 pc., M22- 1 pcs, sockets: M13, M32 and M36, thread glue

Pin punch – 10mm diameter

Pin punch – 20mm diameter

Tape measure

Use gloves

You'll also need a forklift, belts, and a snap link for the belts

You'll need at least 2 people to assemble the machine

### Step 2

Remove the screws on top of the box with the PH2 drill bit and take off all the boards that were held on top of the box



### Step 3

After removing the boards, take out everything in the box

The headstock, gearbox, and body of the machine have to be removed from the box using a forklift  
The red arrow shows the location where to fixture the parts with the belt

Gently place all the items from the box on the floor on either cardboard or bubble wrap so they don't get damaged. We will be using all of them individually in the following steps

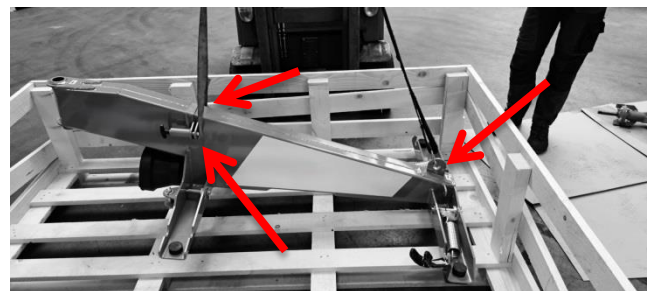
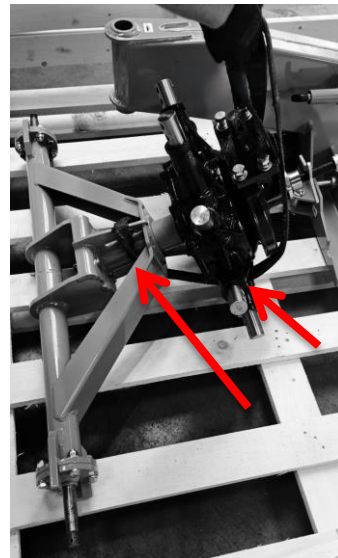

#### **Step 4**

**We start the assembly with the gearbox  
Attach it to the fork lift and hold it slightly above  
the ground  
We will attach the wheels next**



#### **Step 5**

**Take the 2 tandem wheels and attach them to the  
axle at the bottom of the gearbox  
When assembling, make sure the greasing nipples  
are facing up  
Make sure the wheels face outward on the  
backside of the gearbox when you are attaching  
them**



**After the wheels are attached, you can lower the  
gearbox to the ground**

**The red arrow marks a small bag where the  
necessary items for fixturing the wheels to the  
axle are located. The bag is always attached to one  
of the 2 wheels  
It contains 2 washers, 2 nuts, 3 bendable pins, and  
3 rubber sleeves**

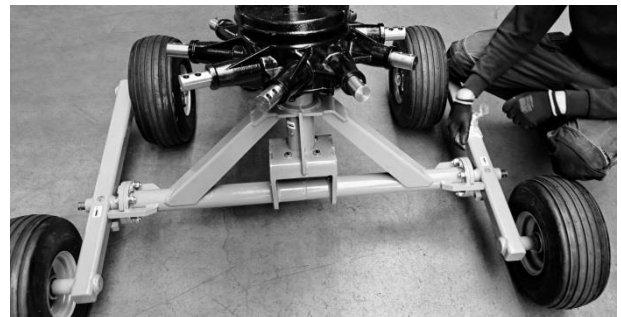

**First place one washer on the screw and then  
screw a nut onto the screw  
To tighten the nut, use the M32 socket on the  
impact driver**

**Make sure not to tighten the nut completely.  
The tandem has to have some room to still move.  
Tighten it just enough, so that the wheels can still  
copy the terrain freely**



**To secure the nut use one pin from the bag and  
run it through the slot in the nut and the hole in  
the screw**

**Use a hammer to insert the pin so its head is  
almost flush with the thread of the screw  
Bend the longer arm of the pin all the way around  
so that it wraps around the top of the screw. Clip  
off about half of the shorter arm of the pin and  
use a hammer to bend it downward, so that it  
interlocks with one side of the nut.**



**After you're done with that, slide the rubber sleeve over the nut and partly over the bushing of the tandem you just fixtured, to seal it**



**Repeat the same procedure of fixturing the tandem on the other side using the remaining parts from the bag**



### Step 6

Now we will attach the gearbox to the body of the machine. To start, you'll need to lift the body with a forklift and bring it closer to the gearbox

Before attaching one to the other, remove the 4 bolts that are attached to the front side of the gearbox, where the drive shaft is coming out. The bolts should come out without any problems, but if they appear to be stuck, use a M22 wrench to loosen them.

We will use them again in step 6.3



### Step 6.1

For easier assembly, we will also remove the 2 shafts on both sides on the rear of the body of the machine

They are located next to the springs

Remove the bendable pin and slide the shaft out of the hole.

Make sure to **ONLY** remove the bendable pin!

On the other side of the shaft, a dowel pin is already installed. That one is not to be removed

Remove both shafts and collect all the washers that were installed on them. You can put them to the side. We will use them later.

You should have 2 shafts (both with a dowel pin in them), 4 thin washers, 4 thick washers, and a bag with extra dowel pins (it is attached with a zip-tie to one of these shafts)

The bag is marked with an arrow on the picture

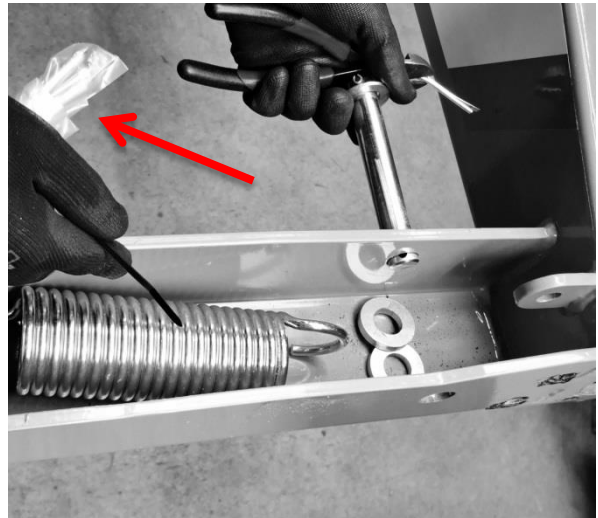

### Step 6.2

Now that these shafts are removed, we can attach the gearbox to the body.

To do that, use the forklift to move the body up or down in the air in order to find the right height to fit the drive shaft of the gearbox into the drive shaft located on the back side of the body.

Make sure the drive shaft of the gearbox slides completely into the drive shaft in the body of the machine.

Do not force it in. You can lightly move the arms of the gearbox to rotate the drive shaft of the gearbox so that its slots fit into the slots in the body.

Once you're done, the gearbox and the machine body should be connected.

Next we will install the blots you removed in step 6



### Step 6.3

Take the bolts (together with the washers that were attached to them) and apply some thread lock glue on the thread.

First lightly screw all 4 bolts into place.



Before we tighten the bolts we have to first check if both ends of the body are leveled.

To do that, take one of the rake arms and temporarily install on the gearbox. We will use it as a gauge to measure the distance between the body of the machine and the rake arm.

Measure the distance as shown on the picture. It should be around 45mm from the top of the rake arm to the upper side of the U-profile (both points are marked by an arrow on the picture)

After you achieve the same measurement on both sides you can tighten the bolts using an M22 wrench and take the rake arm off.

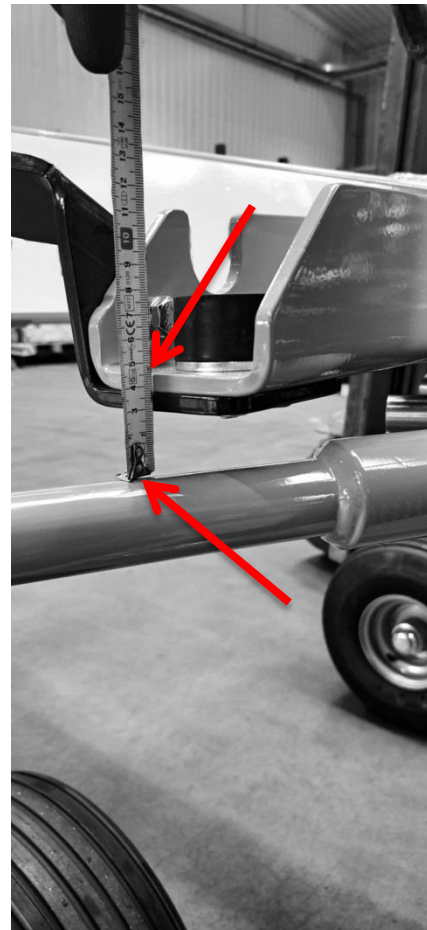



### Step 7

Now we will attach the headstock to the body.  
First unscrew the upper nut from the shaft on the  
headstock and take the shaft out  
You should have one nut, one thick washer, one  
thin washer, and the shaft in your hands now



### Step 7.1

While the headstock is still on the ground, take out the securing pin of the support leg and adjust it so that the leg is completely extended down. Put the securing pin into the hole on top to secure the leg back in place.



### Step 7.2

Now that you'll need to lift the headstock and fixture it to the body.

For that you'll need to lift it which should be done by 2 people.

Fixture it to the front of the body of the machine with the shaft you just removed.

Position the body of the machine as shown on the picture. Insert the shaft from the bottom.



Before completely pushing the shaft through the holes, place the thin washer from the shaft on the upper side of the body (marked with an arrow on the picture). Once the washer is in place you can push the shaft all the way up.

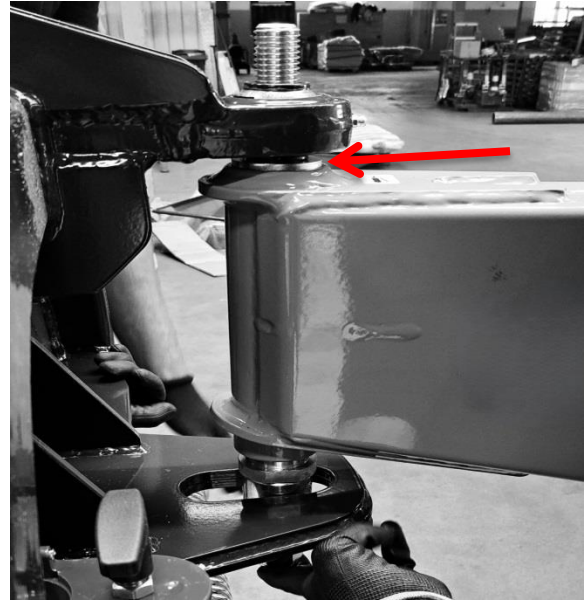

### Step 7.3

Next place the thick washer on top of the screw of the shaft and screw on the nut.



Tighten the upper and lower nut using the M36 socket on your impact driver



**Make sure that after tightening, the upper nut is positioned so that the slots in the nut align with the hole in the thread on the shaft. Run a bendable pin through the hole and secure the nut with it.**

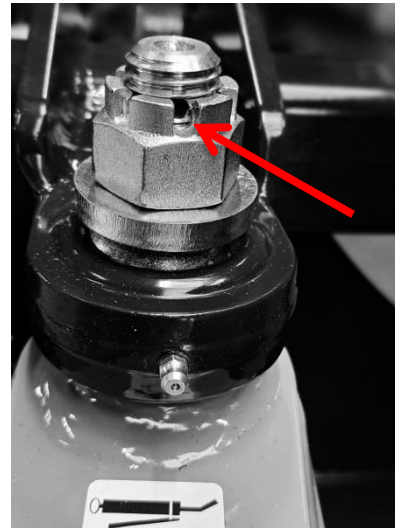

**Bend the longer arm of the bendable pin upwards, and clip off a part of the shorter arm bending it downwards. It should look the same as how you've done it on the tandem wheels.**



**Step 7.4**  
**Finish with placing the last rubber sleeve over the nut to protect it**



### Step 8

Now we will attach the springs from the headstock to the body of the machine

Start by removing the 2 shafts on each side of the front drive shaft of the machine.

Remove the bottom bendable pin and take off the washer



### Step 8.1

Using a hammer and the 10mm pin push remove the shaft by striking it out from the bottom  
Repeat the action on the other side



### Step 8.2

Angle the headstock so that you can fit the spring into the hole you just removed the shaft from.

Using a hammer insert the shaft once again, securing the spring in place



### Step 8.3

For the other side angle the headstock the other way.  
This will be harder now because you already fixture  
one spring into place.

Use leverage to make the installation easier  
Once you position the screw in the right place, fixture it  
with the shaft.



### Step 8.4

Once both shafts are installed, use the dowel pins from  
the bag you removed in step 6.1

Place one washer on the underside of the shaft and  
lock the shaft with the dowel pin

You will use 2 dowel pins from the bag



Use a hammer and the 20mm pin punch to insert the  
dowel pins

Do this for both shafts holding the springs



**Step 9**  
**Installing the barriers**

Start with the right side barrier. To distinguish between the sides of the barriers look at how they are constructed. The right side barrier has a little square metal sheet welded to it (marked with arrow) When mounting the barrier, that metal square should be facing the rear of the machine



**Step 9.1**

Connect the spring to the barrier and the body. Align the bushings with the holes on the U-profiles coming out of the body of the machine.

Align the holes marked by the arrows

We will lock them with the shaft we removed in step 6.1

**For easier installation of the barrier, lock the front part of it with the transport lock.**

**Pull back the pin and fit the hole into the slot as shown in the picture**

**Also, remove the shaft located underneath the transport lock so you can mount the barrier.**

**Remove it the same way as the one in step 6.1 (Remove the bendable pin and slide it out. Do NOT remove the dowel pin from it)**



**Align the holes and slide the shaft into place on both sides, to lock the barrier in place**

**Use the rubber mallet to insert the shafts**

**Use the thick washers in the empty space between the bushing and the U-profile as shown by the arrow**

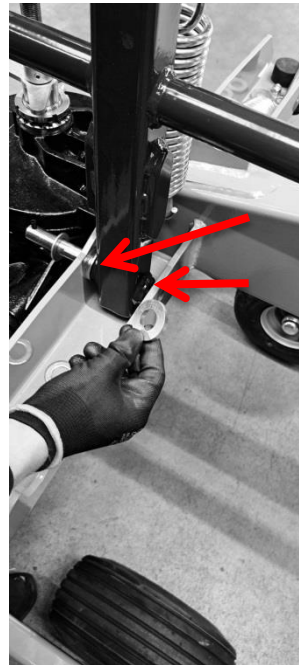

**Add the thin washer on the end of the shaft you just inserted and secure the shaft with the dowel pin from the bag using a hammer and the 20mm pin punch**



**Step 9.2**

**Repeat the same action on the other side of the barrier  
Finish by inserting the thin washer and locking the  
shaft with a dowel pin**



**The installation of the left barrier follows the same  
instructions**

**Remove the shaft under the transport lock  
Attach the spring and for easier installation, lock the  
barrier with the transport lock  
Insert both shafts on the front and back side using a  
hammer.  
Add the thick washers between the bushing and the  
inside of the U-profile  
Lock the shafts with the thin washer and the dowel  
pins from the bag**





### Step 9.3

Now you can lower both barriers.

Next we will install the swath guard to the left barrier.

It will be attached to the left barrier in the spot marked with the arrow



Remove the 4 screws from the swath guard.  
Place the guard on the barrier aligning the holes, you just removed the screws from, with the holes on the barrier



Insert the 4 screws into the holes and screw in the nuts with the washers from the bottom using a M13 wrench and the M13 socket on the impact driver



**Step 9.4**  
On the right barrier install the red reflective triangle. Remove the screws from it and install it through the holes on the metal square sheet on the right barrier.



**Tighten the nuts on the screws using a M13 wrench and the M13 socket on your impact driver**



**Step 10  
Install the rake arms**

**If you're assembling the 9-arm rake insert the arms in the following order:**

- 3 rigid arms**
- Followed by 2 bendable arms**
- Then 2 rigid arms**
- And again 2 bendable arms**



**If you're assembling the 11-arm rake insert the arms in the following order:**

- 3 bendable arms**
- Followed by 3 rigid arms**
- Then 3 bendable arms**
- And then 2 rigid arms**



**Make sure the rakes face the ground when aligning the mounting holes with the holes on the gearbox arms**

**On the handle of the gearbox is a bag with dowel pins used to mount the arms to the gearbox (marked with an arrow on the picture)**



**In the bag are 2 kinds of dowel pins.  
Use them after you aligned the rake arms with the  
holes on the gearbox.**



**Start by inserting the larger ones into the holes using a  
hammer**



**Once the larger ones are in place, use a hammer to  
insert the smaller ones into the bigger ones, to lock  
them in place**

**Use all pins from the bag to fixture the arms**



**Step 11**

**The machine is fully assembled now**

**You should be left with a PTO shaft and a few yellow tarps.**

**The tarps are to be used on the bendable arms when you place the machine in the transport position**

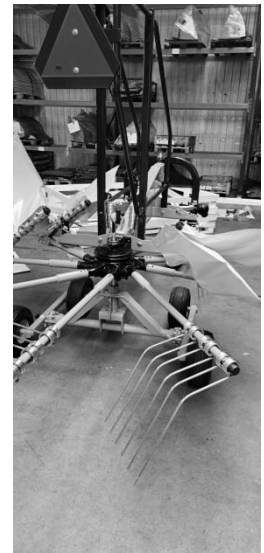

**After installing the PTO shaft in front of the machine, it's ready to be used**





401 Jeffreys Road  
Rocky Mount, NC 27804  
[www.tarrivermfg.com](http://www.tarrivermfg.com)

Tel: 252-822-7140  
Fax: 252-787-5855  
[Sales@tarrivermfg.com](mailto:Sales@tarrivermfg.com)