

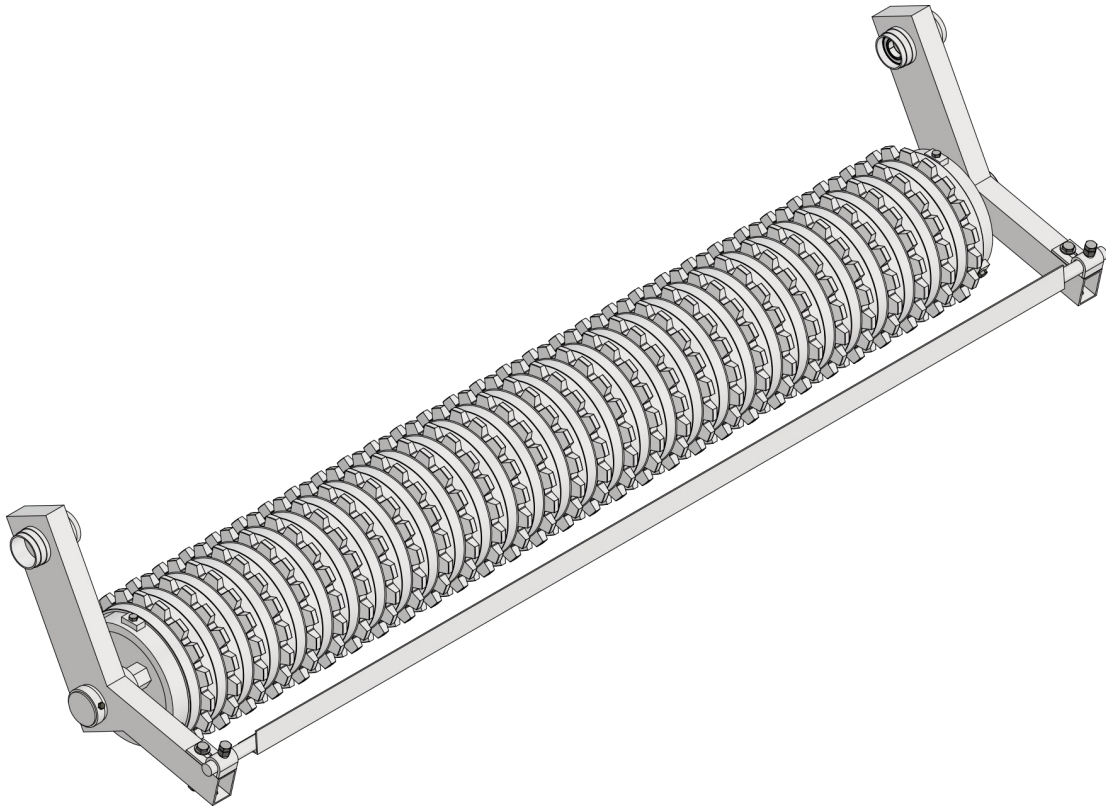

Instructions
Cast Iron Roller Option
SAYA-907



SAYA-CR07 Optional Cast Iron Roller SAYA-907

Removal of OEM Roller

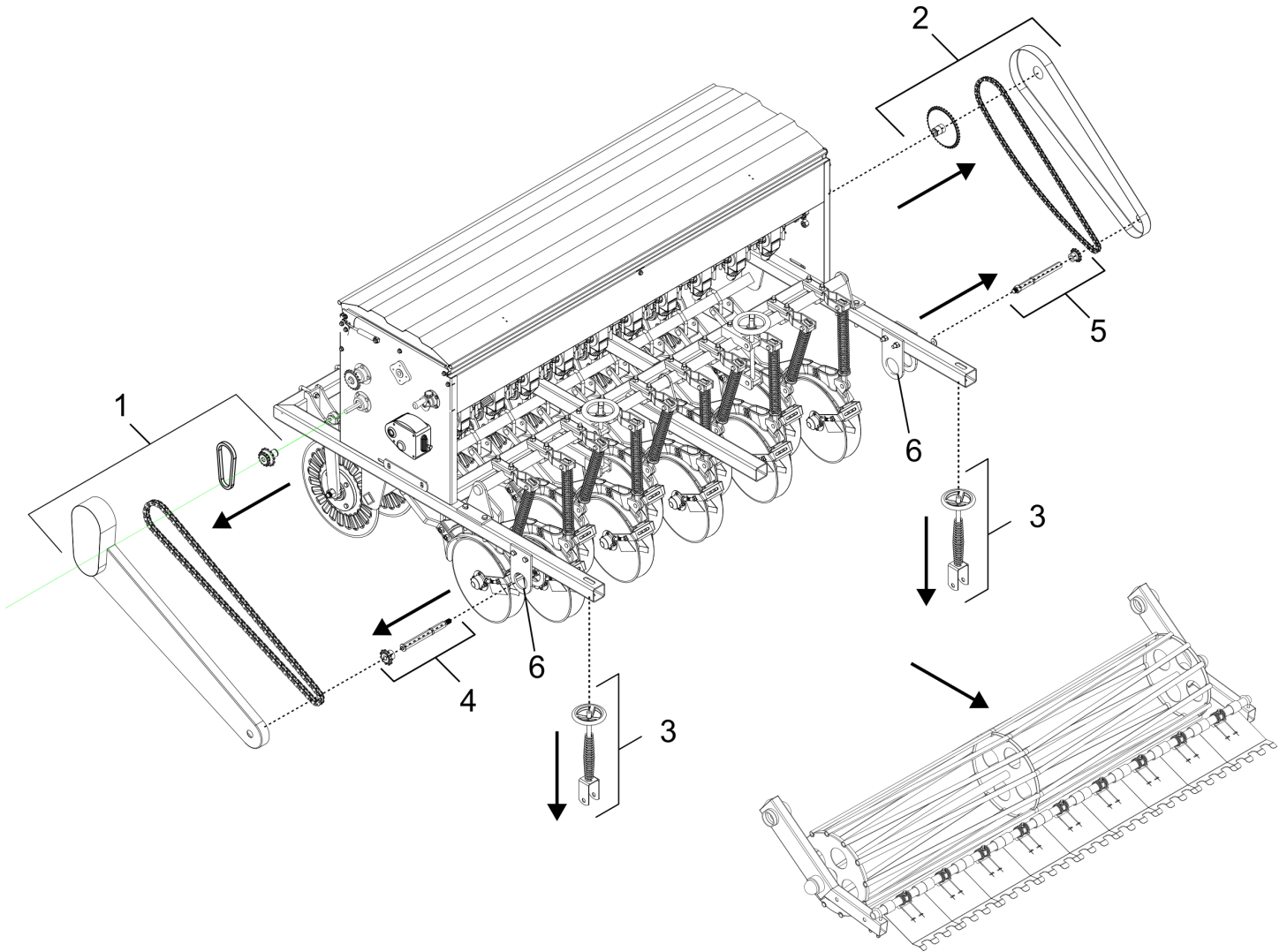

Removal of OEM Roller



WARNING! Prior to removing parts from the machine or installing the Optional Cast Iron Roller, take all necessary precautions to ensure the safety of the installer (s). Wear necessary PPE (personal protection equipment). It is advised to perform the work on a hard, level surface, such as a concrete shop floor or other hard appropriate surface. Never allow bystanders in work area or between the tractor and machine. If the machine is attached to a tractor, shut off the engine, remove key, set parking brake and block the wheels of the tractor to prevent movement. Serious injury or death can occur!

Note: Original parts removed from the machine should be stored in dry location in case the Cast Iron Roller Kit is removed at any point and the Original Drive Roller is re-installed.

Step 1. Remove LH Roller Chain Cover, LH Roller Chain (long), Front Hopper Roller Chain (short) and Front Hopper Sprocket 14T x 20T.

Step 2. Remove RH Roller Chain Cover, RH Roller Chain and 40 Tooth Chain Sprocket.

Step 3. Remove one of the Downforce Adjustment Assemblies by first removing the Locking Nut and Roller Downforce Adjustment Wheel. Next remove the M16x70 Shoulder Pin and Cotter Pin from the lower part of the assembly. The Downforce Adjustment Assembly can then be slide out from the SAYA Frame. Repeat for the opposite side.

Step 4. Remove LH Drive Sprocket and Small Sprocket Shaft from the LH Roller Arm. These parts must be removed prior to removing Roller Assembly. *(Note: The Small Sprocket Shaft is used for the Cast Iron Roller Install).*

Step 5. Remove RH Drive Sprocket and Small Sprocket Shaft from the RH Roller Arm. These parts must be removed prior to removing Roller Assembly. *(Note: The Small Sprocket Shaft is used for the Cast Iron Roller Install).*

Step 6. Loosen (do not remove) Bracket Roller Arm Brackets securing the Drive Roller Assembly to the Frame. At this point in time, the Roller Assembly can be removed from the machine.

Installation of Cast Iron Roller Option

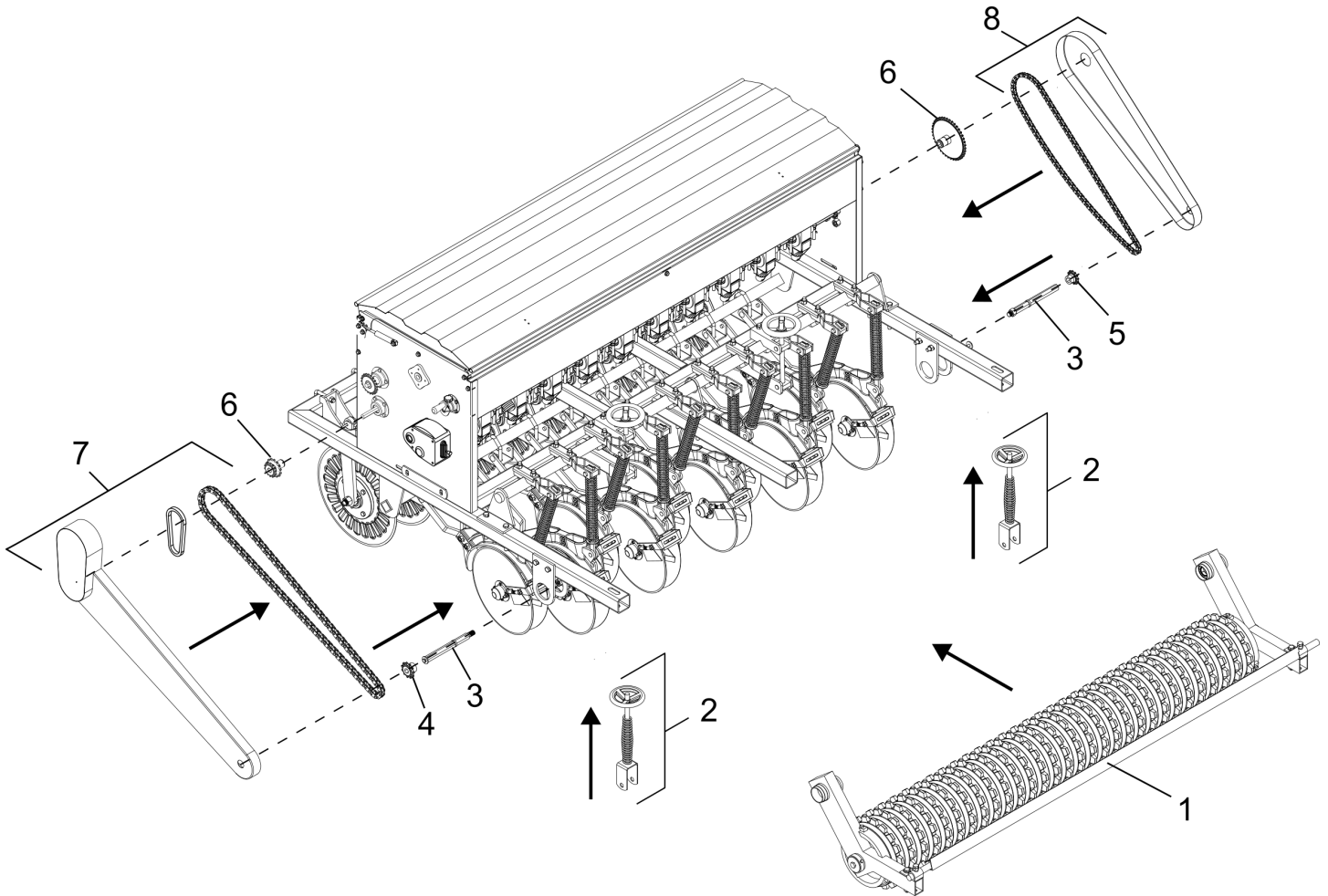

Installation of Cast Iron Roller Option

Note: Do not tighten hardware until all parts are in place and aligned.

Step 1. Move the Cast Iron Roller Assembly in place, lining up the Roller Arms with the Roller Arm Brackets. Leave Roller Arm Brackets loose for now.

Step 2. Attach the Downforce Adjustment Assemblies (original part) to the SAYA Frame and Roller Arms.

Step 3. Insert (1) Small Sprocket Shaft (original part) in the each of the Roller Arms.

Step 4. On the LH Roller Arm, slide Sprocket *SA4112 10Tooth, #50 Chain on the Small Sprocket Shaft. Do not tighten at this time.

Step 5. On the RH Roller Arm, slide Sprocket *SA4114 9Tooth, #40 Chain on the Small Sprocket Shaft. Do not tighten at this time.

Step 6. Attach *SA4111 Sprocket, 16T x 14T to the LH side of the machine and *SA4113 Sprocket 33T to the RH side of the machine.

Step 7. Attach LH Roller Chain (long), Front Hopper Roller Chain (short) and Roller Chain Cover. Note: Note: Note: LH Roller Chain has to be modified due to change in sprocket size. Extra links, half links and master links are included in the Cast Iron Roller Kit. Once Sprockets, Chain are in alignment, lock down Sprockets.

Step 8. Attach RH Roller Chain and Roller Chain Cover. Note: RH Roller Chain has to be modified due to change in sprocket size. Extra links, half links and master links are included in the Cast Iron Roller Kit. Once Sprockets, Chain are in alignment, lock down Sprockets.

Step 9. Tighten all hardware to proper torque specs. A torque chart is included in the SAYA Operator's Manual.

***Parts included in Cast Iron Roller Kit**

Page left blank intentionally

Page left blank intentionally

BELC 
RESOURCES
EQUIPMENT

401 Jeffreys Road
Rocky Mount, NC 27804
www.br-equipment.com

Tel: 252-822-7140
Fax: 252-787-5855
Sales@br-equipment.com